

# RAMSOND®

## Digital Inverter Generator

### SINEMATE SERIES

#### Model 1500



**OPERATING INSTRUCTIONS**  
PLEASE READ THIS MANUAL CAREFULLY  
BEFORE USING MACHINE



# CONTENT

<b>1.Preface.....</b>	<b>1</b>
<b>2.Safety instruction.....</b>	<b>2</b>
<b>3.Safety label and locations.....</b>	<b>4</b>
<b>4.Component identification.....</b>	<b>5</b>
<b>5.Pre-operation check.....</b>	<b>6</b>
<b>6.Start the engine.....</b>	<b>10</b>
<b>7.Generator use.....</b>	<b>14</b>
<b>8.Stop the engine.....</b>	<b>22</b>
<b>9.Maintenance.....</b>	<b>24</b>
<b>10.Transportation and storage.....</b>	<b>29</b>
<b>11.Troubleshooting.....</b>	<b>31</b>
<b>12.Specification.....</b>	<b>33</b>
<b>13.Exploded parts view.....</b>	<b>34</b>
<b>14.Parts list.....</b>	<b>35</b>
<b>15.Limited Warranty .....</b>	<b>36</b>

# PREFACE

Thank you for purchasing our generator

This manual covers operation and maintenance of Sinemate 1500.

All information in this publication is based on the latest product information available at the time of approval for printing.

We reserve the right to make changes at any time without notice and without incurring any obligation.

No part of this publication may be reproduced without written permission.

This manual should be considered a permanent part of the generator and should remain with it if it is resold.

Pay special attention to statements preceded by the following words:

## **▲ WARNING**

It indicates a strong possibility of severe personal injury or death if instructions are not followed.

## **▲ CAUTION**

It indicates a strong possibility of severe personal injury or death if instructions are not followed.

If a problem should arise, or if you have any questions about the generator, consult an authorized dealer.

## **▲ BE CAREFUL**

The generators are designed to give safe and dependable service if operated according to instructions. Read and understand the Owner's Manual before operating the generator. Failure to do so could result in personal injury or equipment damage.

---

## Safety Instructions

---

### Warning



- ◆ The generator is designed to give safe and dependable service if operated according to instructions. Read and understand this manual carefully before operating the generator, or it may cause serious injury and equipment damage.

### Warning



- ◆ Exhaust contains poisonous carbon monoxide. Do not operate generator in confined area. Be sure to operate the generator in a well-ventilated environment or with an aerator. Using a generator indoors will kill you in minutes. Never use in the home or in a partly enclosed area such as garages. Only use outdoors and far from open windows doors and vents.

### Warning



- ◆ The muffler becomes very hot during operating and remains hot for a while after stopping the engine. Be careful not to touch the muffler while it is hot. Let the engine cool before storing the generator indoor.
- ◆ The engine exhaust system will be heated during operation and remain hot immediately after stopping the engine. To prevent burns, pay attention to the warning marks attached to the generator.

### Be careful



- ◆ Do not parallel connect other cables to receptacles, use special jack, or it may cause an electrical shock.

### **⚠ Warning**

- ◆ Gasoline is extremely flammable and is explosive under certain conditions. Refuel in a ventilated area with engine stopped .
- ◆ Keep away from cigarette, smoke and sparks when refueling the generator. Always refuel in a well-ventilated location.

### **⚠ Warning**

- ◆ Connection for standby power to a building electrical system must be made by a qualified electrician. The connection must isolate the generator from utility power, and must comply with all applicable laws and electrical codes. Improper connections to a building electrical system can allow electrical current from the generator to backfeed into the utility lines. Such backfeed may electrocute utility company workers or others who contact the lines during a power outage, and the generator may explode, or cause fires when utility power is restored.

### **⚠ Warning**

- ◆ To avoid accidents and equipment damage, check generation system every time before starting engine.
- ◆ Keep the generator a distance of at least 1 yard from other equipment during operation.
- ◆ Keep the generator horizontal when running. If generator tilts, fuel may leak.
- ◆ Generator operators must be trained, must know how to stop the generator quickly and understand the operation of all controllable parts. Untrained operators should not be allowed to use this equipment.
- ◆ Keep children and pets away from operation area.
- ◆ Keep away from rotating parts during operation.
- ◆ The generator is a potential source of electrical shock when misused. Do not operate it with wet hands or in any wet location
- ◆ Do not operate the generator in rain or snow and let it get wet.

---

## Safety Label and Locations

---

These labels warn you of potential hazard that can cause serious injury. Read the labels and safety notes and precautions described in manual carefully.

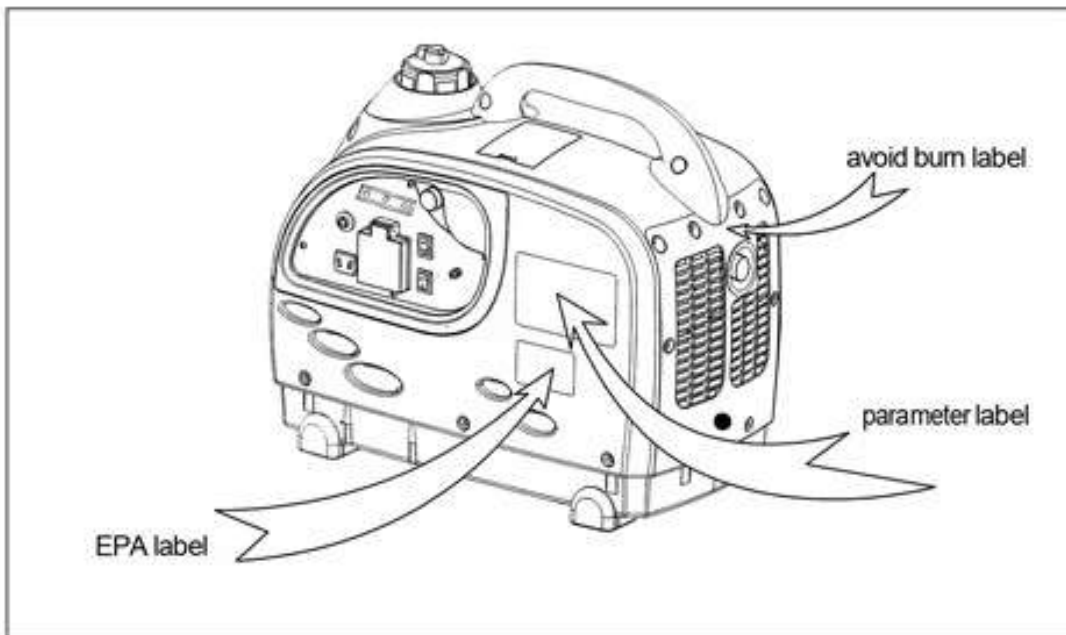
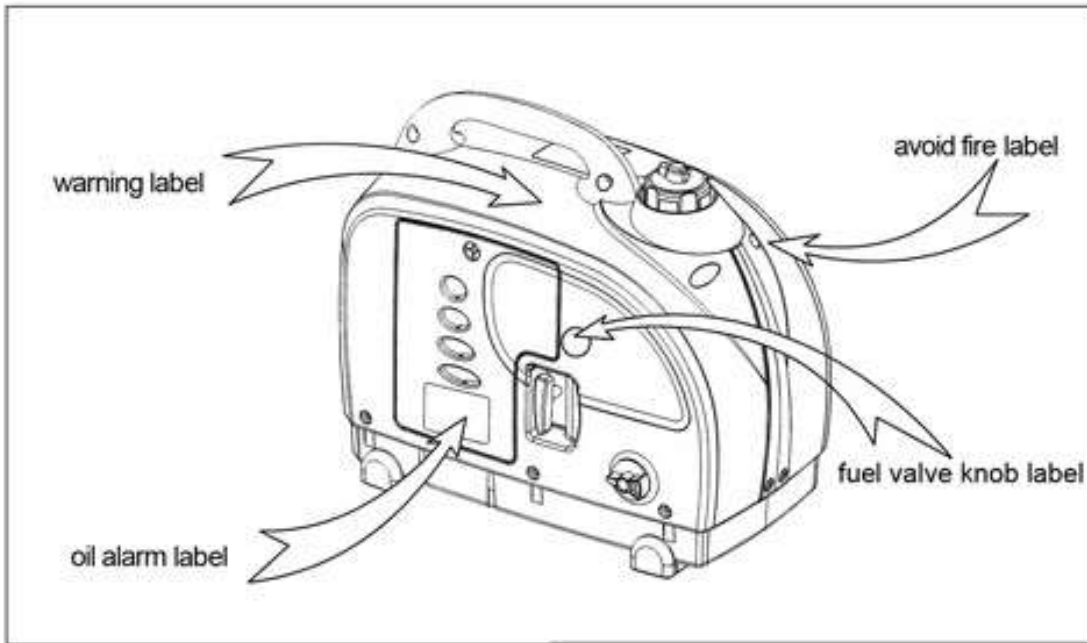

---

## Component Identification

---

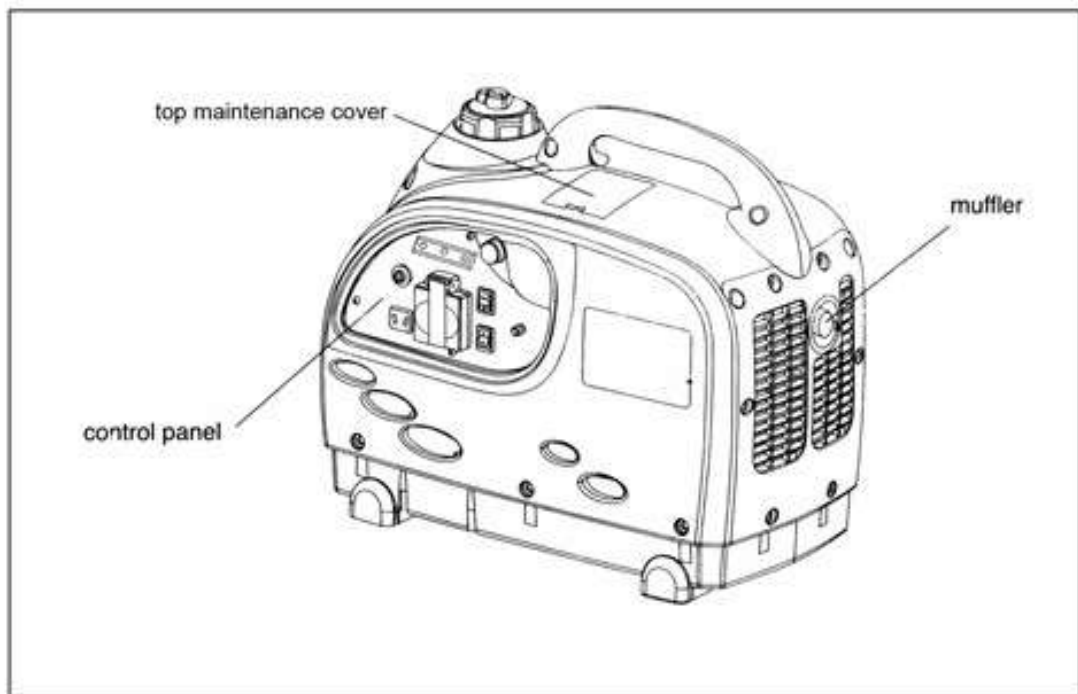
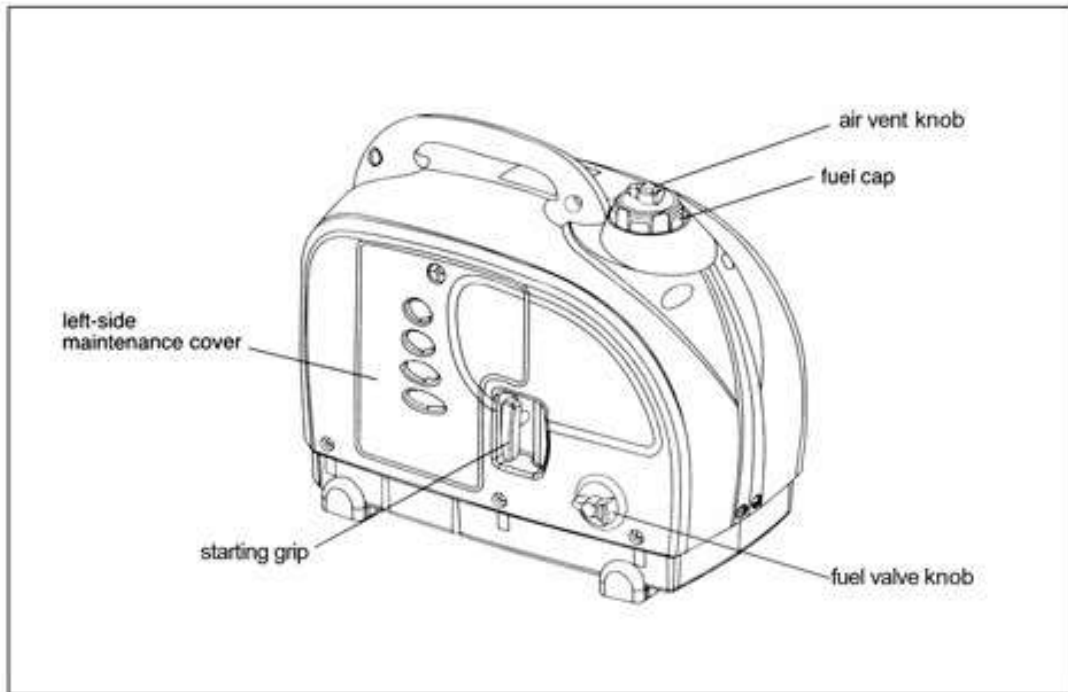

## Control panel

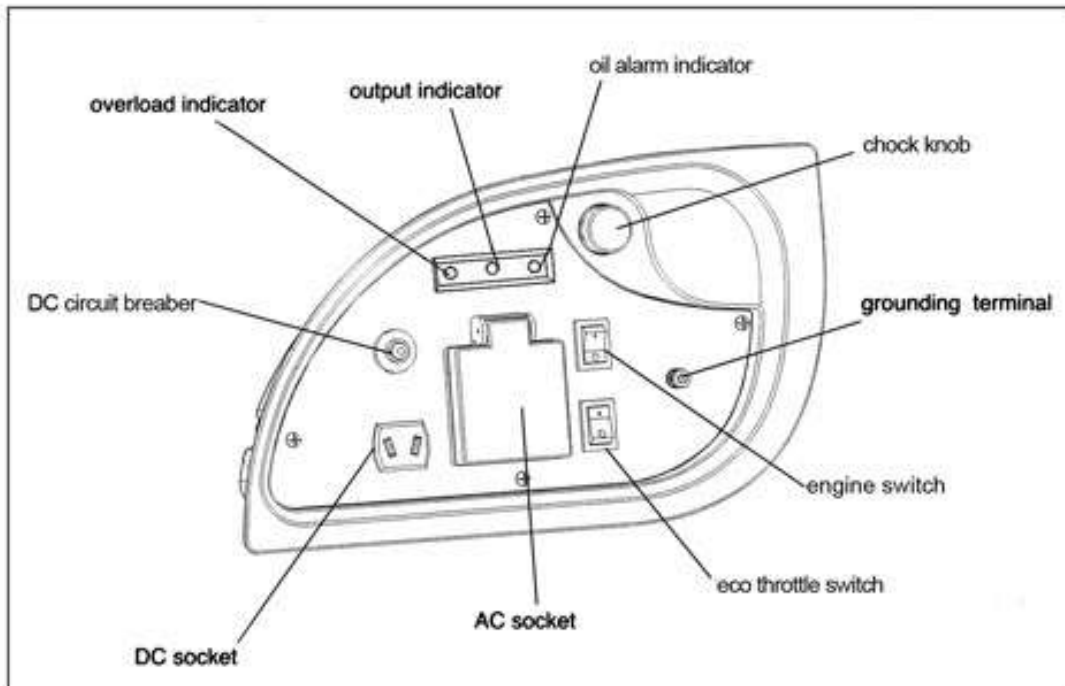

## Smart Throttle

To minimize fuel consumption during operation, the engine automatically idles when the electrical appliance is disconnected. It will return to the proper speed when the electrical appliance is connected.

### **⚠ Caution**

- ◆ Smart throttle system does not operate effectively, if the electrical appliance requires the momentary electric power.
- ◆ When high electrical loads are connected simultaneously, turn the Smart throttle switch to the OFF position to reduce voltage vibration.
- ◆ In DC operation, turn the Smart throttle switch to the OFF position.

---

## Pre-operation check

---

### **⚠ Caution**

- ◆ Be sure the generator is on a level surface with engine stopped before starting.



## 1. Check engine oil level

### **▲ Be careful**

- ◆ Engine oil is a major factor affecting engine performance and service life. Using non-detergent and 2-stroke engine oils will damage the engine and are not recommended, and will void warranty!
- ◆ Use high-detergent, qualified 4-stroke engine oil, certified to meet or exceed U.S. automobile manufacture's requirements for API Service Classification SG, SF.
- ◆ Select the appropriate viscosity for the average temperature in your area.

SAE viscosity grades:

Single viscosity	10W					
		20W				
			30			
				40		
					40	→
Multi viscosity			20W-40, 20W-50			→
			15W-40, 15W-50			→
			10W-40			→
		10W-30				

Loosen the cover screw and remove the maintenance cover.

Remove the oil filler cap and wipe the dipstick with a clean rag. Check the oil level by inserting the dipstick in the filler hole without screwing it in.

If the oil level is below the end of the dipstick, refill the recommended oil up to the top of the oil filler neck.

### **▲ Be careful**

- ◆ Running the engine with insufficient oil can cause serious engine damage.
- ◆ The Low Alarm System will automatically stop the engine before the oil level falls below the safe limit. To avoid the inconvenience of an unexpected shutdown, it is still advisable to visually inspect the oil level regularly.

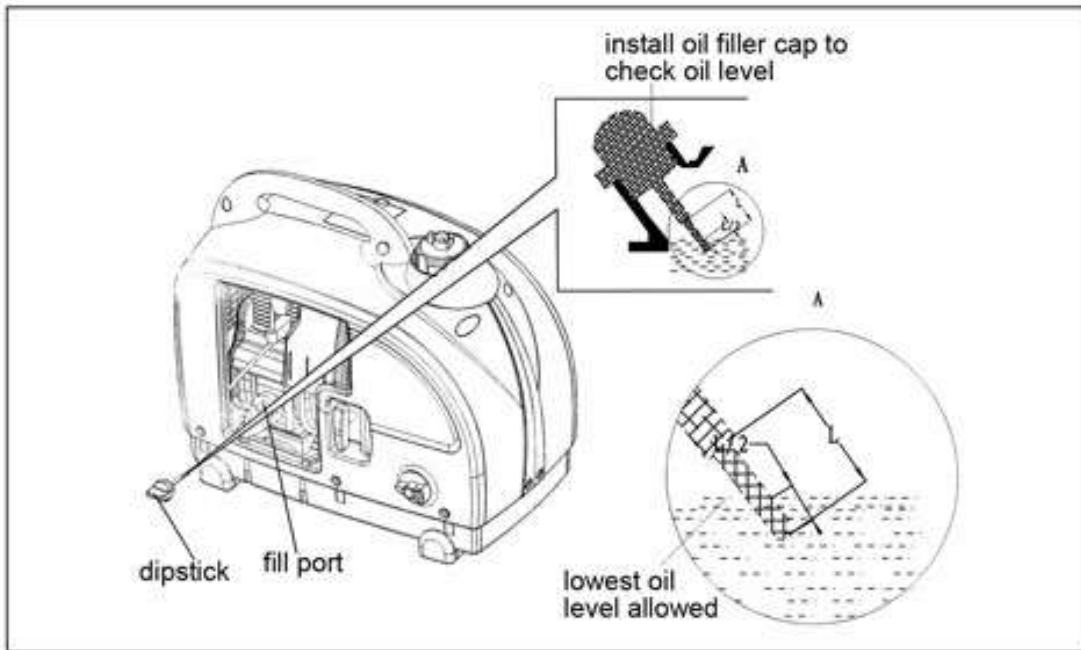

## 2、 Check the fuel level

Use automotive gasoline (unleaded or low-leaded gasoline is preferred to minimize combustion chamber deposits)

If the fuel level is low, refuel until the level increased to the specified mark.

Never use stale or contaminated gasoline or an oil/gasoline mixture.

Avoid getting dirt and water in the fuel tank.

Tighten the fuel filler cap securely after adding fuel.

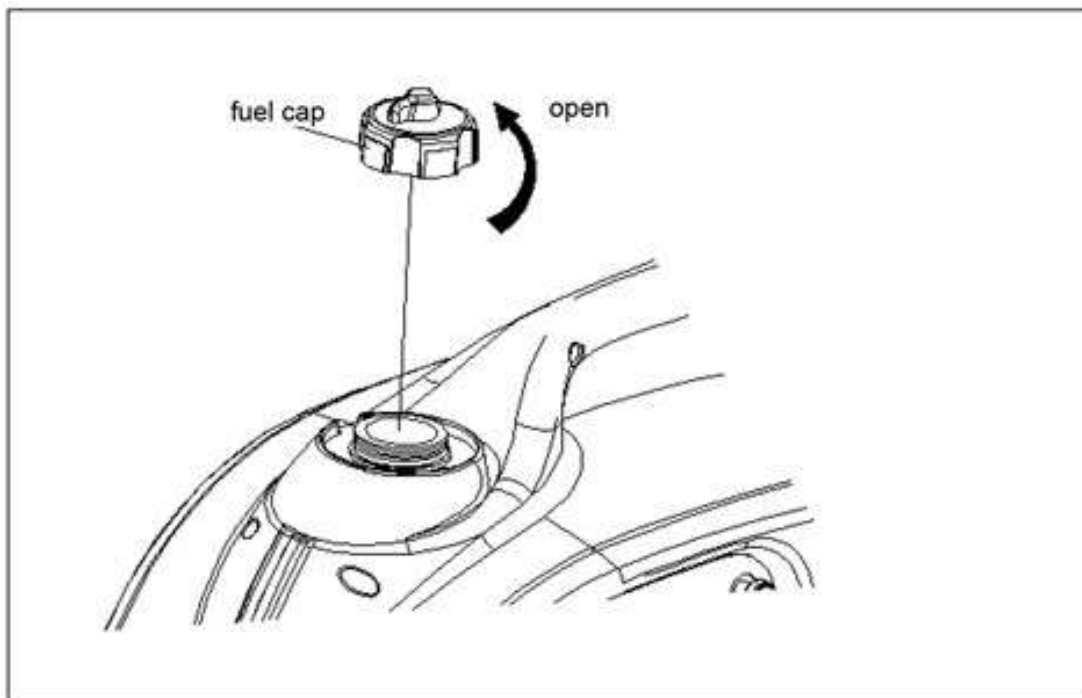

## **▲ Note**

- ◆ When transporting, turn the air vent knob to the OFF position.

## **▲ Warning**

- ◆ Gasoline is extremely flammable and is explosive under certain conditions.
- ◆ Do not smoke or allow flames or sparks where the generator is refueled or where gasoline is stored. Refuel in a well-ventilated area with the engine stopped.
- ◆ Do not overfill the fuel tank (there should be no fuel above the upper limit mark). After refueling, make sure the tank cap is closed properly and securely.
- ◆ Be careful not to spill fuel while filling the tank. Spilled fuel or fuel vapor may ignite. If fuel spills, wipe away until dry. Do not start the engine until area is dry and vapor free.
- ◆ Avoid prolonged and repeated contact with gas or breathing of vapor. Keep out of reach of children.

### 3、 Check air filter

Check air filter, and be sure it's clean and works well.

- Loosen the cover screw and remove the maintenance cover
- Loosen the screw under the air filter box.
- Pull the air filter cover down 1.25inches according to (a) and remove the air filter cover according to (b).
- Remove the air filter iron clip and element. Clean and change the air filter element if necessary.
- Clean or replace the air filter element after reinstalling air filter

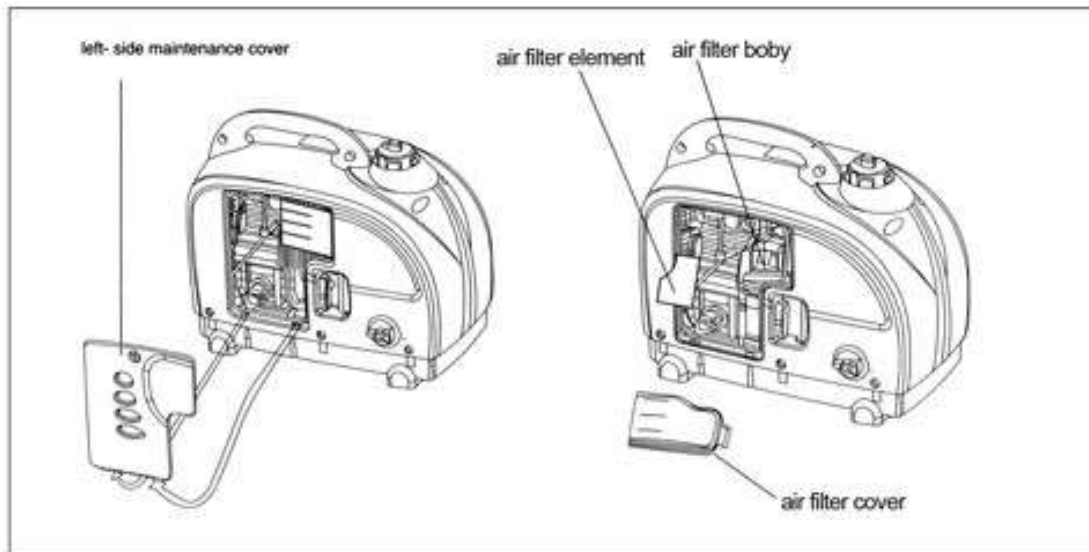

## **▲ Be careful**

- ◆ Never operate the engine without air filter. Rapid engine wear will result from contaminants, such as dust and dirt, being drawn through the carburetor into the engine.

It is normal for a little oil to appear under the air filter box if the generator is running for a long period of time, or a lot of oil is in the engine. Wipe up excess oil after each use and after stopping the generator.

---

## **Start the engine**

---

Before starting the engine, disconnect any plug from the AC socket.

1. **Turn the air vent knob on the fuel cap counter-clockwise**

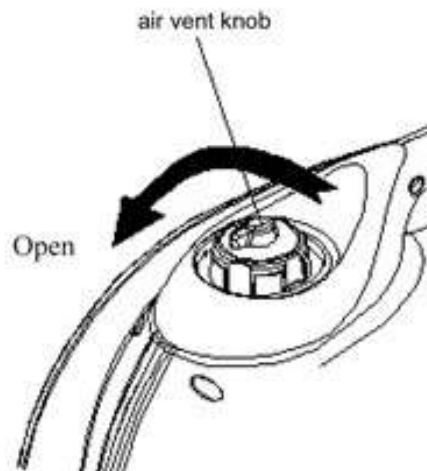

2. **Turn the fuel valve knob to the ON position**

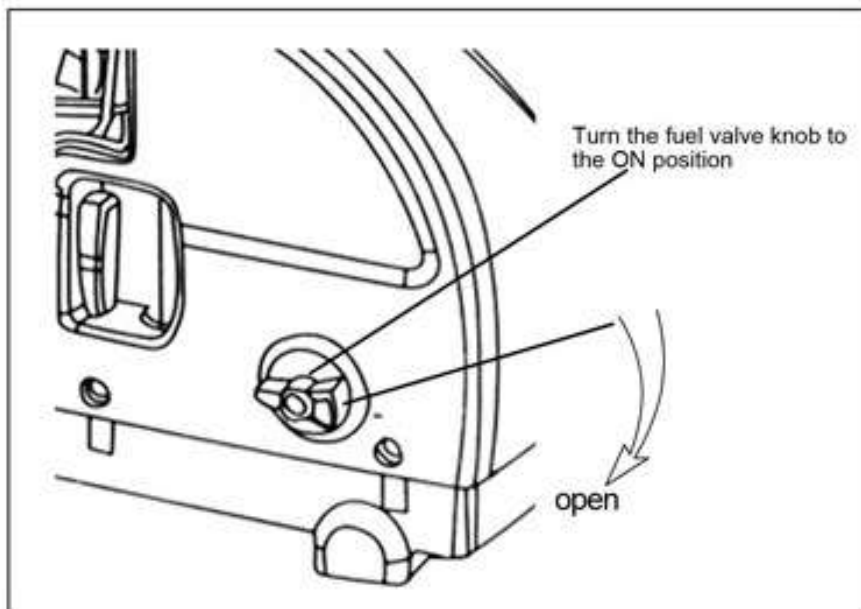

3. To start a cool engine, pull out the choke knob completely to the CLOSED position. To restart a warm engine, press the choke knob in completely to the OPEN position

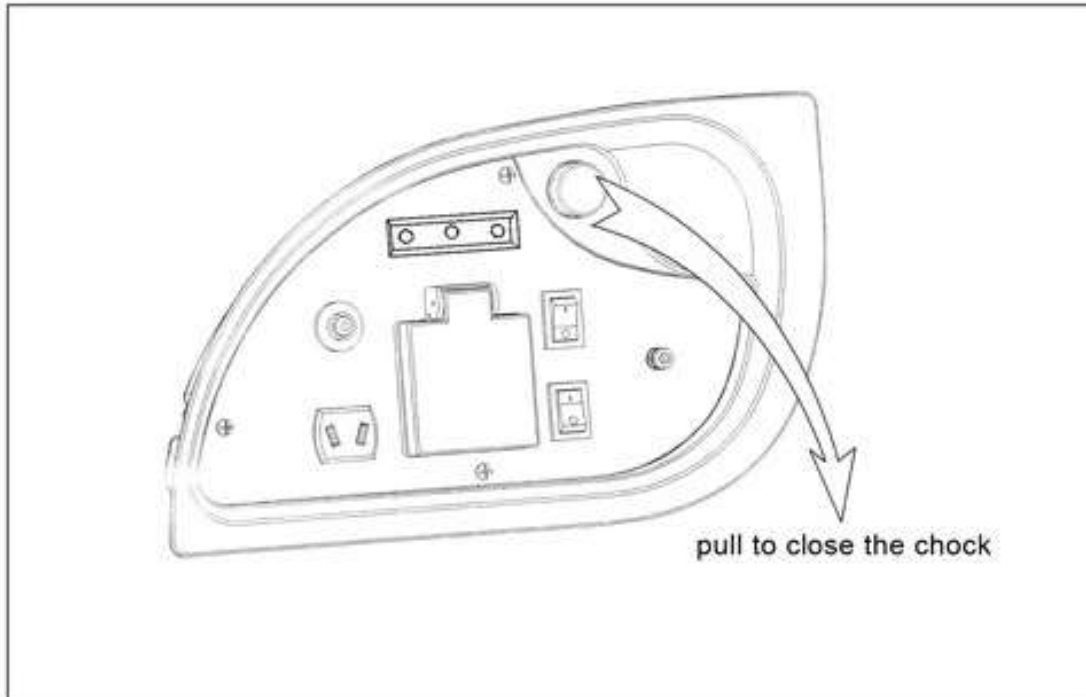

**⚠ Be careful**

Controlling the choke position is the key to starting the engine, it may take several practice attempts before you master the choke.

To restart a hot engine, leave the choke in the OPEN position or pull it out half way. To

restart a warm engine, pull out the choke 1/3 or 1/2 way.

A hot engine will not start if there is too much gasoline in the cylinder. If this happens, wait 5-10 minutes before retrying. Press the chock in completely to the OPEN position and the engine should start.

The engine will stop automatically when it is out of gasoline. Refuel accordingly to the instructions defined earlier in this manual. To restart the engine after refueling pull the chock out completely, then pull the starting handle 2 or 3 times so that gasoline enters the carburetor. Adjust the chock according to the above instructions.

4. Turn the engine switch to the ON position.

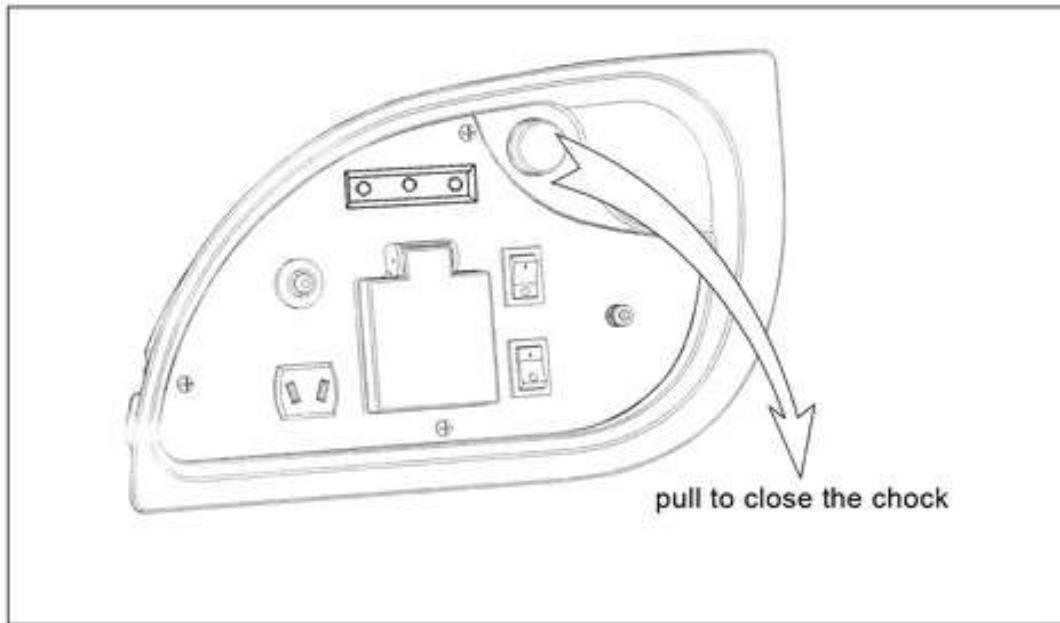

5. Pull the starting grip lightly until resistance is felt, then pull briskly.

**⚠ Be careful**

- ◆ Never allow the starting grip to snap back, return it slowly by hand.
- ◆ Grasp the carrying handle firmly to prevent the generator from falling over when pulling the starting grip.

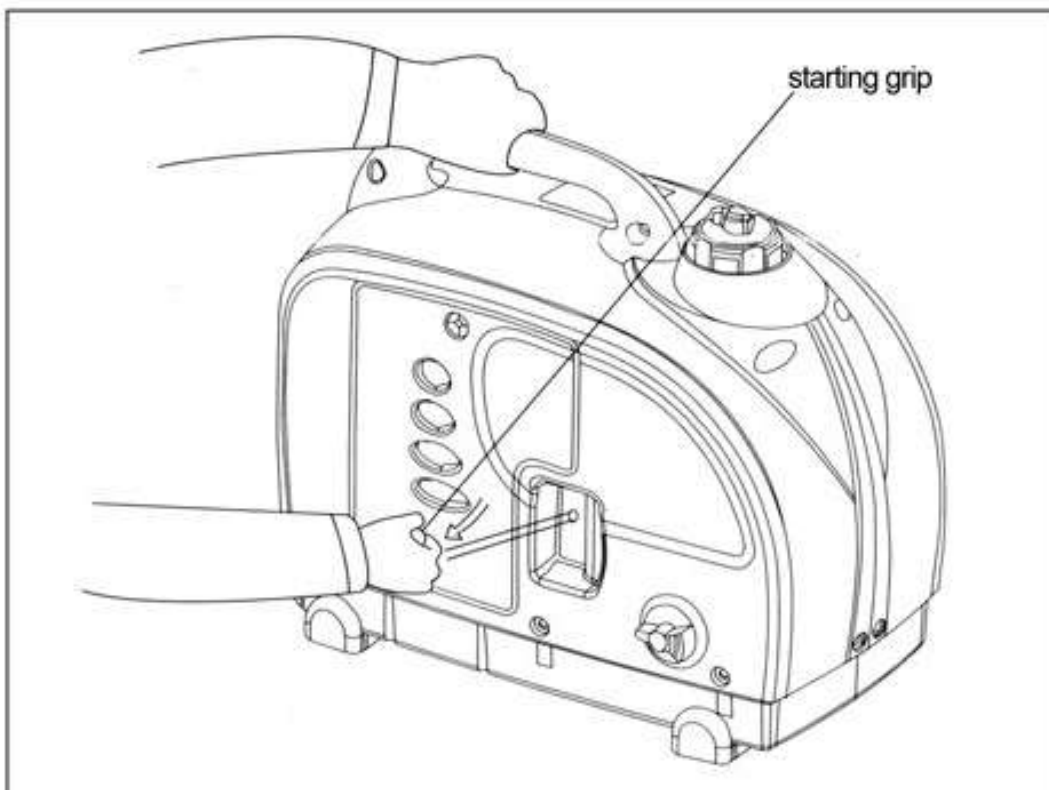

6. After the engine starts, allow the engine to run continuously and warm up.
7. Press the choker in completely after the engine is started.

**▲ Note**

- ◆ If the engine stops and will not restart, check the engine oil level before troubleshooting in other areas.

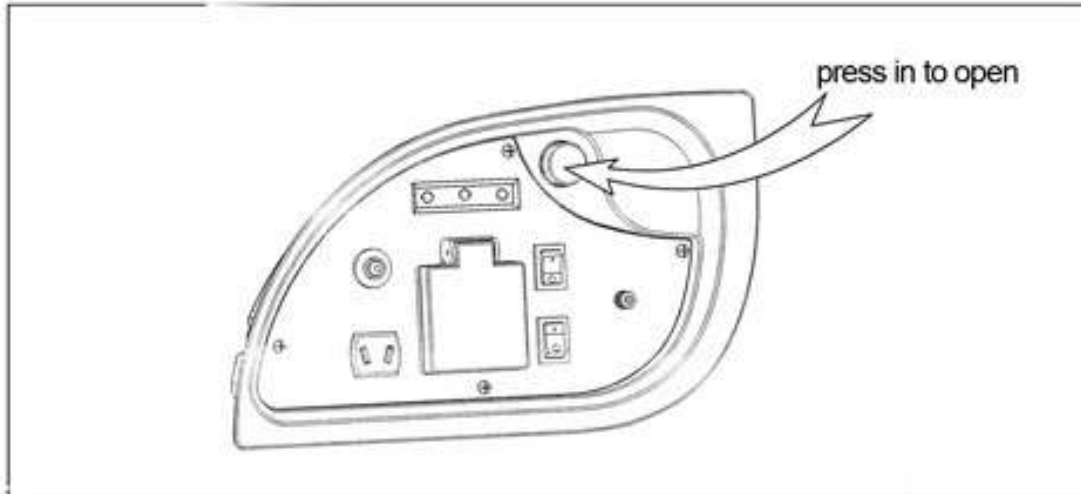

## High Altitude Operation

At high altitude, the standard carburetor air-fuel mixture will be excessively rich. Performance will decrease, and fuel consumption will increase.

High altitude performance can be improved by installing a smaller diameter main fuel jet in the carburetor and by readjusting the pilot screws. If you always operate the generator at altitudes higher than 1500m (5000feet) above sea level, have your authorized dealer perform these carburetor modifications.

Even with suitable carburetor setting, engine horsepower will decrease approximately 3.5% for each 300m (1000 feet) increase in altitude. The affect of altitude on the horsepower will be greater than this if no carburetor modification is made.

**▲ Note**

- ◆ Operation of the generator at an altitude lower than the carburetor is set for may result in reduced performance, overheating, and serious engine damage caused by an excessively lean air/fuel mixture

---

## Generator Use

---

### Warning

- ◆ TO AVOID ELECTRIC SHOCK, BE SURE TO THAT GENERATOR IS PROPERLY GROUNDED. Connect a length of heavy wire between the generator's ground terminal and an external ground source.
- ◆ Connections for standby power to a building electrical system must be made by a qualified electrician and must comply with all applicable laws and electrical codes. Improper connections can allow electrical current from the generator to backfeed into the utility lines. Such backfeed may electrocute utility company workers or others who contact the lines during a power outage, and when utility power is restored, the generator may explode, burn or cause fires in the building's system.

### Be careful

- ◆ Do not exceed the rated power.  
Total wattage of all appliances connected must be considered.
- ◆ Do not exceed the current limit specified for any one socket.
- ◆ Do not connect generator to any household circuit, otherwise, it may destroy generator or home electric equipment.
- ◆ Do not use generator for any purpose other than its intended use. Failure to follow these instructions could result in serious injury. Do not parallel connect generators or lengthen the exhaust pipe.
- ◆ Extension cords are not recommended. If an extension cable is required, be sure to use only a rubber sheathed flexible cable. (IEC245 or equivalent)
- ◆ Limit length of extension cables: 60m for cables of 1.5mm<sup>2</sup> and 100m for cables of 2.5mm<sup>2</sup>.  
Long extension cables will reduce usable power due to resistance in the extension cable.
- ◆ Keep the generator away from other electric cables or wires such as commercial power supply lines.

### Note

- ◆ The DC socket can be used while the AC power is in use. If you use both at the same time, be sure not to exceed the total power for AC and DC.
- ◆ Most appliance motors require more than their rated wattage for start-up



## AC power use

1. Start the engine and make sure the output indicator (green) stays on.
2. Insure that all loads have been turned off, and then put the plug into the socket.

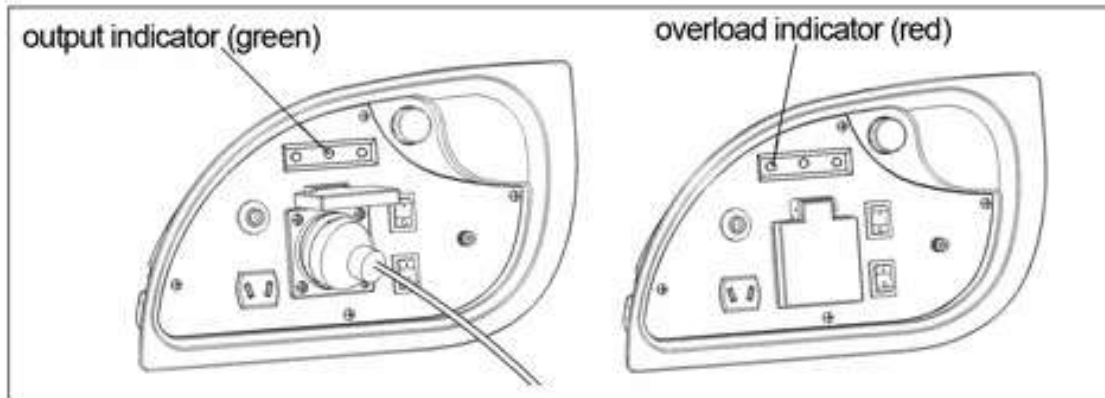

### **▲ Be careful**

- ◆ Substantial overloading that continuously lights the overload indicator light (red) may damage the generator. Marginal overloading that temporarily lights the overload indicator light (red) may shorten the service life of the generator.
- ◆ Be sure that all appliance are in good working order before connecting them to generator. If an appliance begins to operate abnormally, becomes sluggish or stops suddenly, turn it off immediately, disconnect the appliance, and determine whether the appliance has a problem, or if the rated load capacity of the generator has been exceeded.

## Output and overload indicator:

The output indicator (green) will remain ON during normal operating conditions.

If the generator is overloaded, or there is a short circuit in a connected appliance, the overload indicator (red) will go on. The overload indicator (red) will stay on, and the current to the connected appliance will be shut off.

**STOP THE ENGINE IMMEDIATELY IF THE OVERLOAD INDICATOR LIGHT TURNS ON. Do not restart until you have found the reason for the overload.**

## **▲ Be careful**

- ◆ BEFORE CONNECTING ANY APPLIANCE TO THE GENERATOR, BE SURE IT IS IN PROPER WORKING ORDER AND THAT IT DOES NOT EXCEED THE POWER RATING OF THE GENERATOR.
- ◆ Be sure all equipment is turned off before plugging in the power cord.

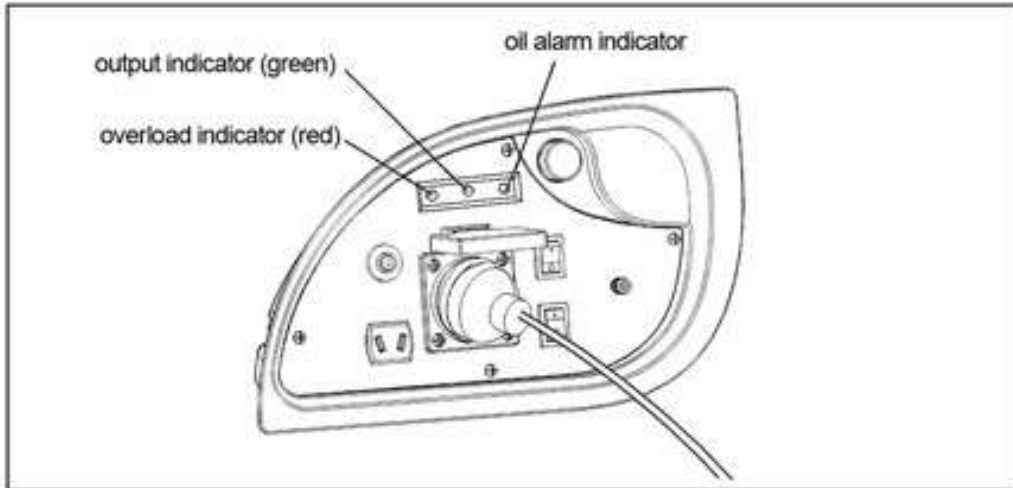

## **▲ Be careful**

- ◆ When an electric motor is started, both the overload indicator (red) and the output indicator (green) may stay on simultaneously. This is normal if the overload indicator (red) stays off after about 4 seconds.
- ◆ If the overload indicator (red) stays on after the engine has been started, discontinue use and consult an authorized repair person. **DO NOT CONTINUE TO USE.**

### 1. Connect ground

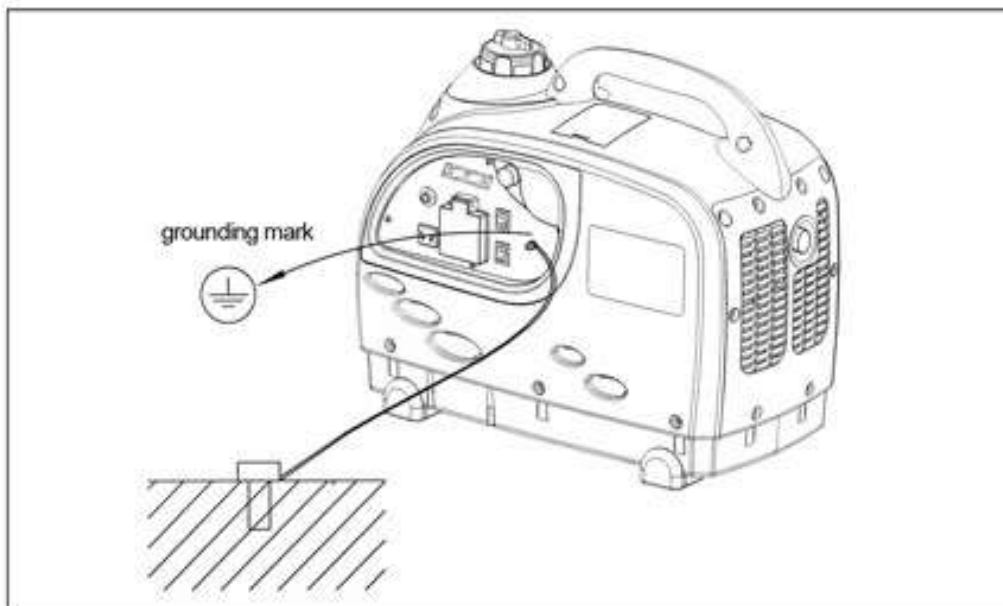

2. Start the engine as page 11

If the overload indicator stays on, TURN OFF THE ENGINE IMMEDIATELY. Restart the engine after the overload indicator turns off.

3. Make sure the electrical appliance is turned off, before plug it in the AC socket.

### **▲ Be careful**

◆ BE SURE ALL APPLIANCES ARE IN THE OFF POSITION BEFORE CONNECTING TO THE GENERATOR. FAILURE TO DO SO MAY RESULT IN SERIOUS INJURY, DEATH, AND EQUIPMENT DAMAGE. ALWAYS KEEP UNTRAINED PEOPLE, CHILDREN AND PETS AWAY FROM THE GENERATOR WHILE IN USE.

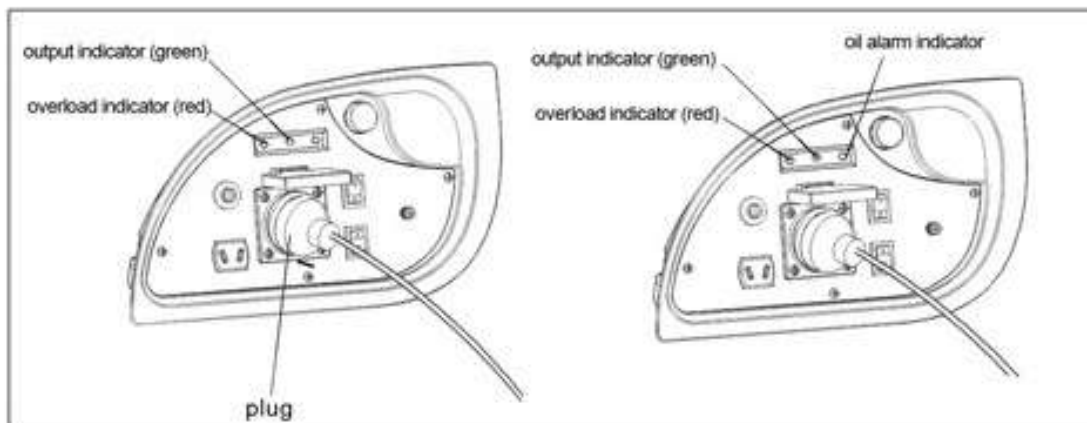

4. Turn on the equipment after output indicator (green) turns on

If there is overload or malfunction in equipment, output indicator (green) will turn off and overload indicator (red) will turn on with no power output. TURN THE ENGINE OFF IMMEDIATELY and follow the instructions above.

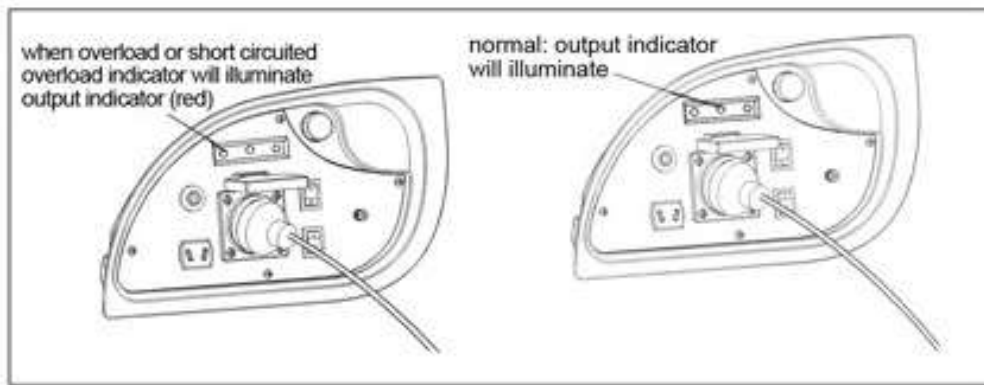

**▲ Be careful**

- ◆ If the equipment is an inductive load, it will need more power for starting. Overload indicator and output indicator will turn on at the same time for a short period, that's normal. Red indicator turns off but green indicator still keeps on after equipment starts.

## DC power use

For charging 12V automotive batteries:

AC Parameter:

	Idling voltage (V)	Loading voltage (V)	Loading current (A)
Opening the smart throttle	22	12	6
Closing the smart throttle	27	13	8.5
AC Max. output power	37	13.5	8.5

The generator cannot sense a sensibility load with the same power which the manual indicates. It only can sense 40%-70% power which the manual indicates.

### **⚠ Note**

- ◆ When using the DC output, turn Smart Throttle to the OFF position. The DC current will be below 5A if turning on the Smart Throttle without AC current output.
- ◆ When charging batteries, person must be present to monitor the voltage. Stop charging when the voltage of the batteries is above 16V. Or it may cause battery explosion, resulting in serious injury or death.

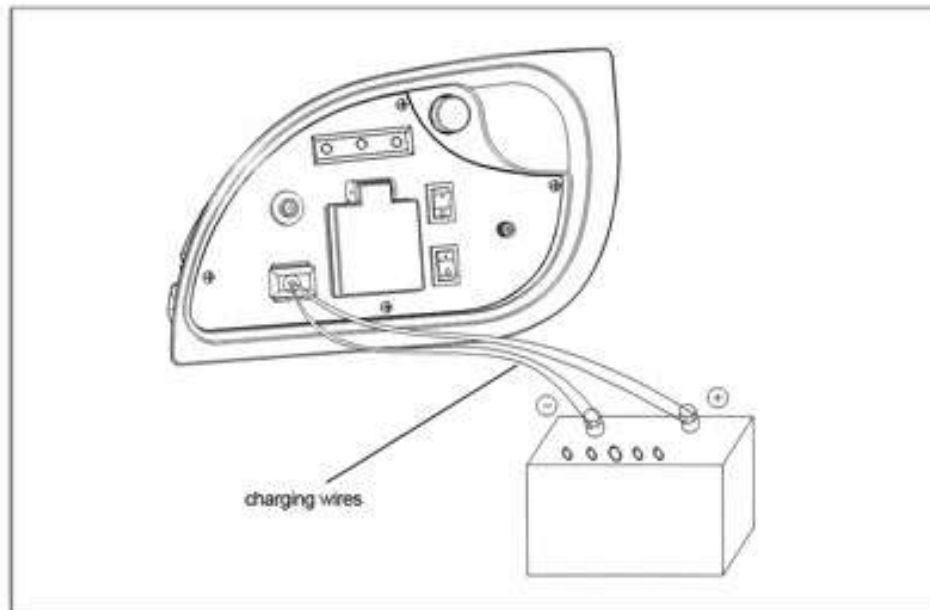

### **⚠ Warning**

- ◆ To prevent the possibility of creating a spark near the battery, connect charging cable first to the generator, then to the battery. Disconnect cable first at the battery.
- ◆ When charging auto car batteries, disconnect ground wire of the batteries first, and reconnect it after charging. This will avoid a short circuit or spark if the ground wire touches the body of auto cars by accident.

### **⚠ Be careful**

- ◆ Do not start the car when generator is connected to batteries, or it may destroy generator.
- ◆ Make sure the positive battery terminal is connected to the positive charging cord. Do not reverse the charging cables, or serious damage to the generator and battery may occur.

### **⚠ Warning**

- ◆ the battery gives off explosive gases: keep spark, flames and cigarettes away. Provide adequate ventilation when charging. Failure to do so may result in shock, property damage, fire and/or serious injury.
- ◆ Avoid body contacting with fuels, oils and lubricants used in the generator. If swallowed, seek medical treatment immediately. Do not induce vomiting if fuel is swallowed. For skin contact, immediately wash with soap and water. For eye contact, immediately flush eyes with clean water and seek medical attention.
- ◆ Keep out of reach of children, pets and untrained people.

#### 2. Start engine

- DC power and AC power can be used at the same time.
- An overloaded DC circuit may trip DC circuit breaker. If this happens, wait a few minutes before pushing in the circuit breaker to resume operation.

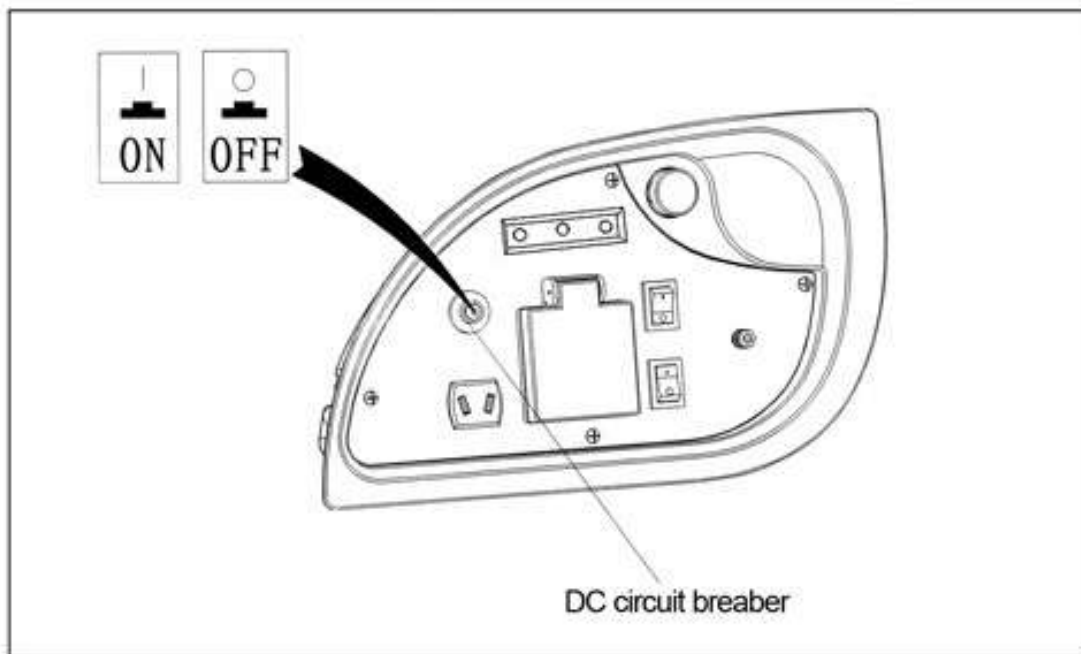

### Oil alarm system

Oil alarm system is designed to avoid engine damage from not enough oil in crankcase. Oil alarm system will stop engine automatically before oil level in crankcase gets below the safety line (ignition indicator will stay on during cranking)

The engine will not restart after it is stopped by the oil alarm system. If the oil alarm system indicator (red) stays on during cranking, the engine will not start. Add more oil (see pre-operation check)

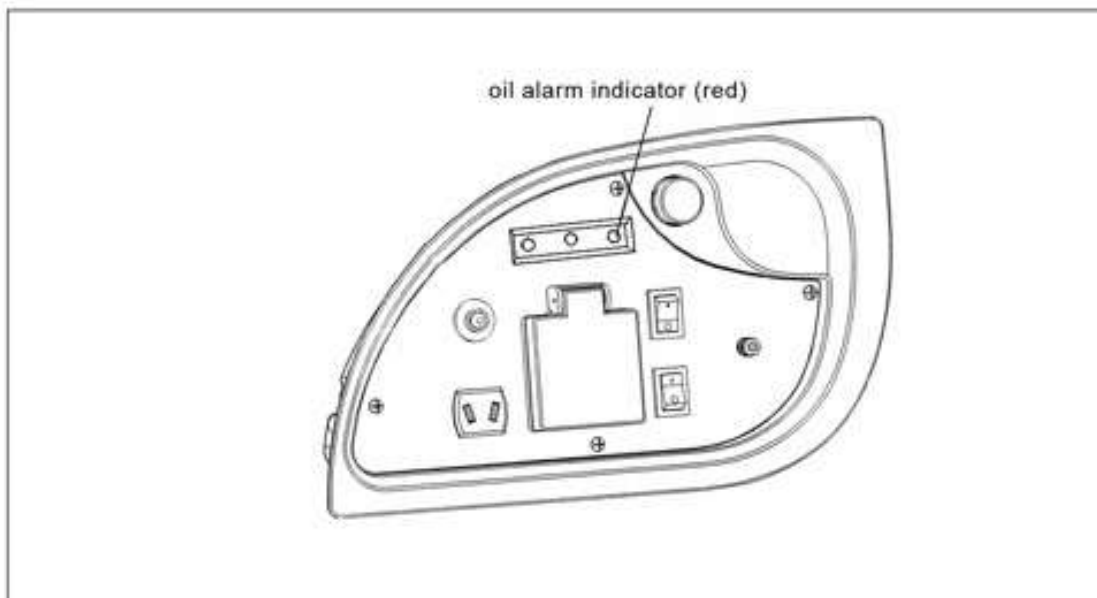

---

## Stop engine

---

To stop engine in an emergency, simply turn the engine switch to the OFF position.

Normal usage

1. Unplug appliances from the generator sockets.

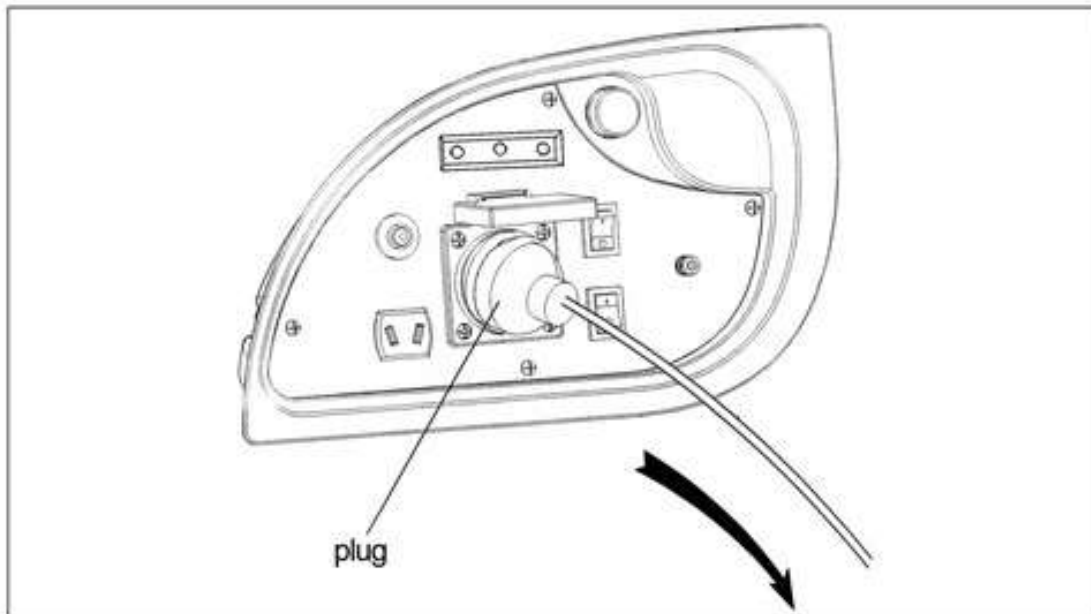

2. Turn the engine switch to the OFF position.

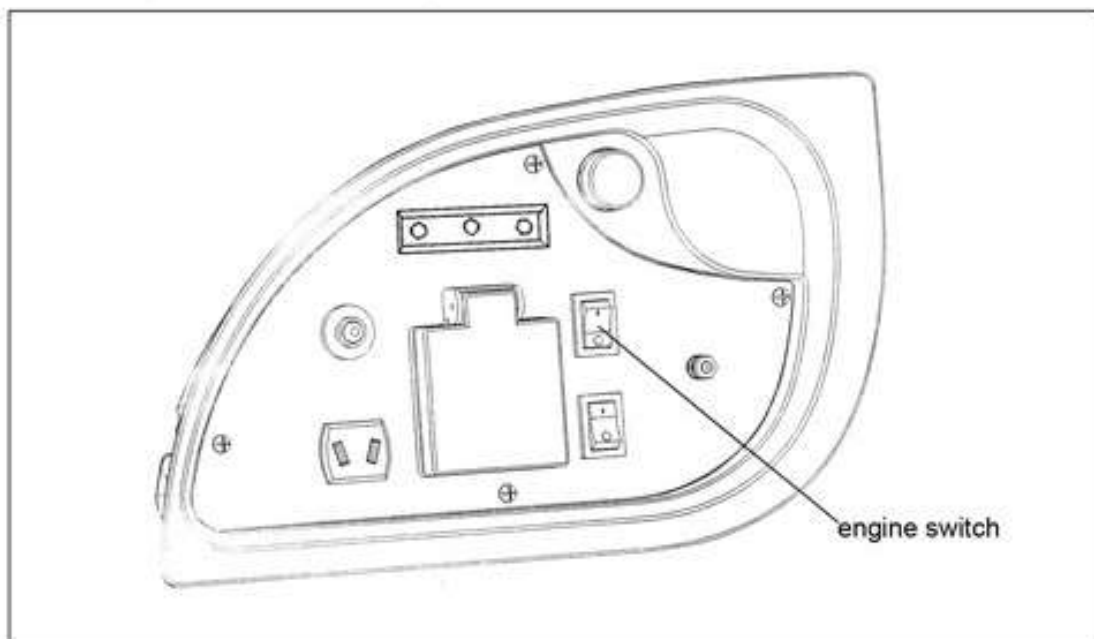



3. Close the air vent knob and turn fuel valve to the OFF position

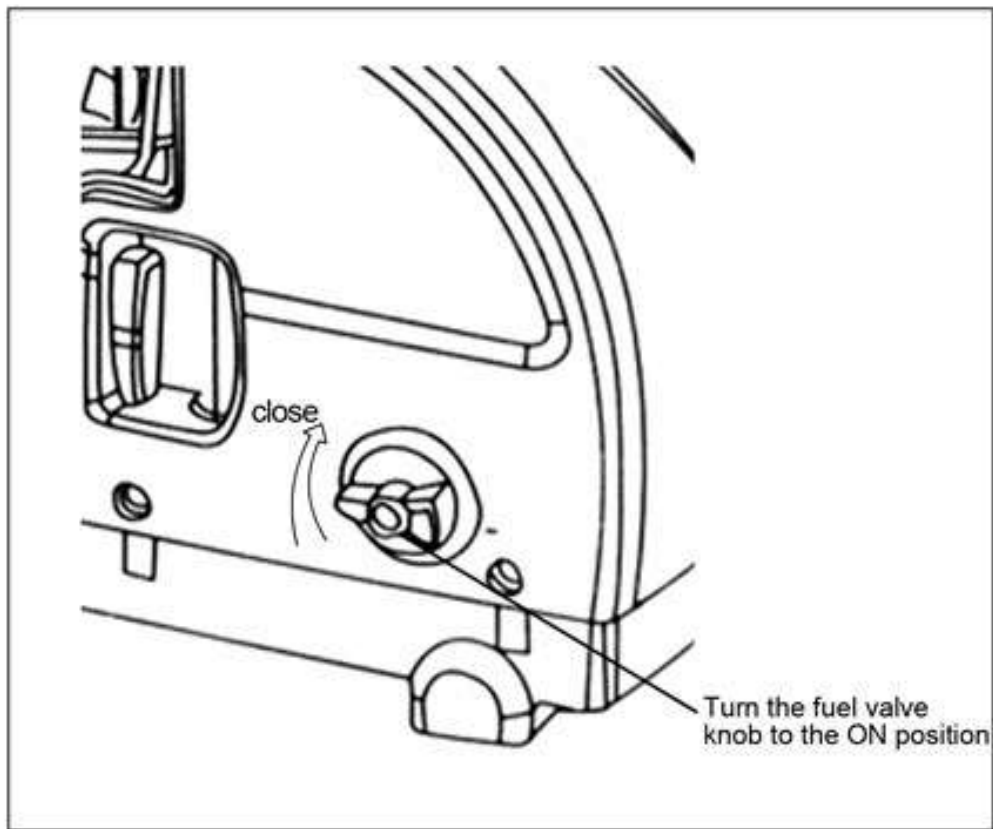

**▲ Be careful**

◆ Make sure that the air vent knob and fuel cap are closed and engine switch is off when finished using, transporting and storing the generators.

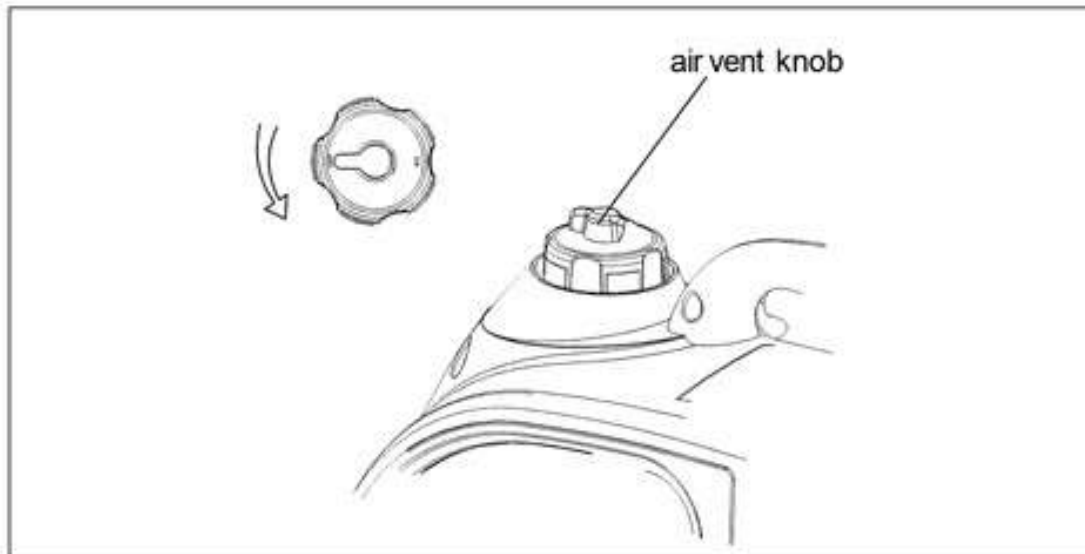

# Maintenance

The purpose of the maintenance and adjustment schedule is to keep the generator in the best operating condition.

Inspect or service as scheduled in the table below

## ⚠ Warning

- ◆ Stop engine before servicing. If servicing requires operating generator, be sure to operate the generator in a ventilated environment. Exhaust fumes contain the poisonous gas carbon monoxide. Carbon Monoxide is a colorless, odorless gas that, if inhaled, can cause serious injury or death.

## ⚠ Caution

- ◆ Repairs to the generator should be done by trained licensed people only.

### Maintenance Schedule

Perform at every indicated month or operating hour interval.

ITEM	Maintenance Procedure	Regular service period ①				
		Each use	Each month 20 HRS	Each 3 months or 50 HRS	Each 6 months or 100 HRS	Each year or 200 HRS
Engine Oil	Check	●				
	Replace		●		●	
Air cleaner	Check	●				
	Clean			● ②		
Spark plug	Clean & adjust				●	
Combustion chamber	Clean				●	
Valve clearance	Check & adjust					● ③
Fuel tank and filter tank	Clean					● ③
Fuel line	Check	Every 2 years 【replace if necessary as (3)】				

(1) Normal maintenance interval

(2) Service more frequently when used in dusty areas.

(3) The Maintenance Schedule is based on the 25 °C. If the temperature is above 30 °C, decrease the output power or shorten the time to change oil

Temperature (°C)	Time for changing oil (hour)	Recommended power factor
25	normal	100%
30	18	95%
35	15	85%
40	12	70%

### 1. Change oil

Drain the used oil while the engine is warm. Warm oil drains quickly and completely.

#### **▲ Be careful**

- ◆ Turn the engine switch and air vent knob to the OFF position to reduce the possibility of fuel leakage.

- Tilt the generator.
- Loosen the screw and drain the oil completely.
- Retighten the screw.
- Add the recommended oil and check the oil level
- Gently shake the generator to make the float rise after adding new oil.

Oil tank capacity: 0.25L

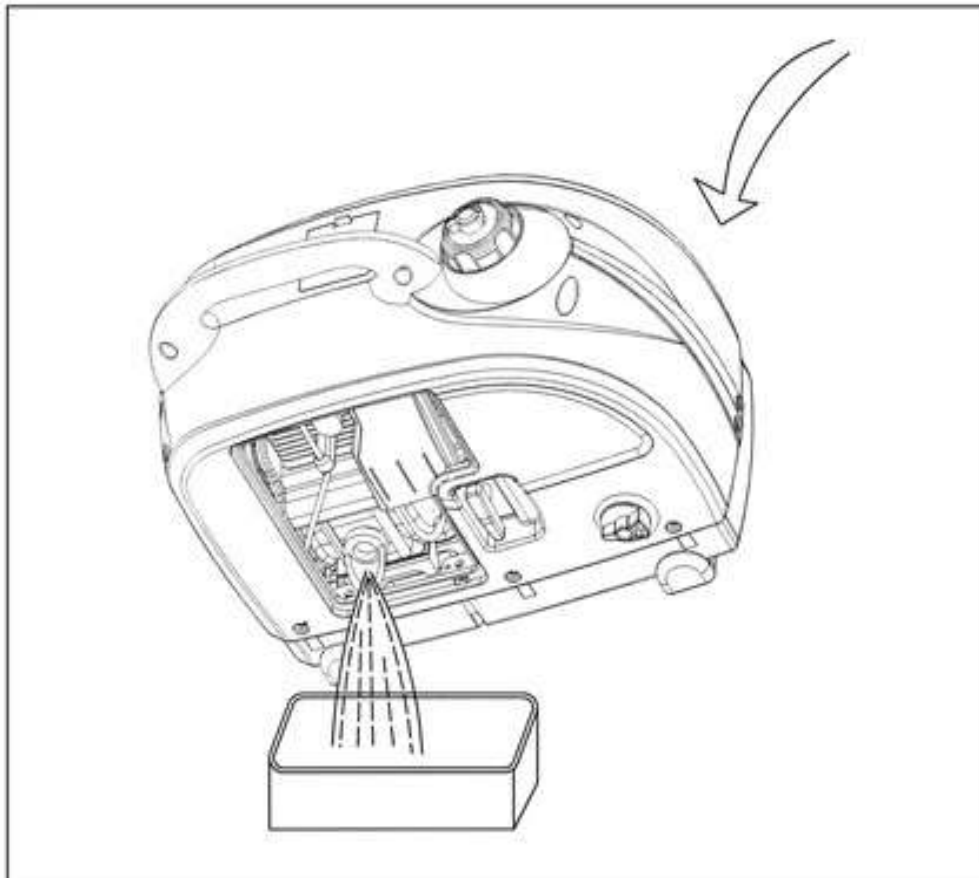

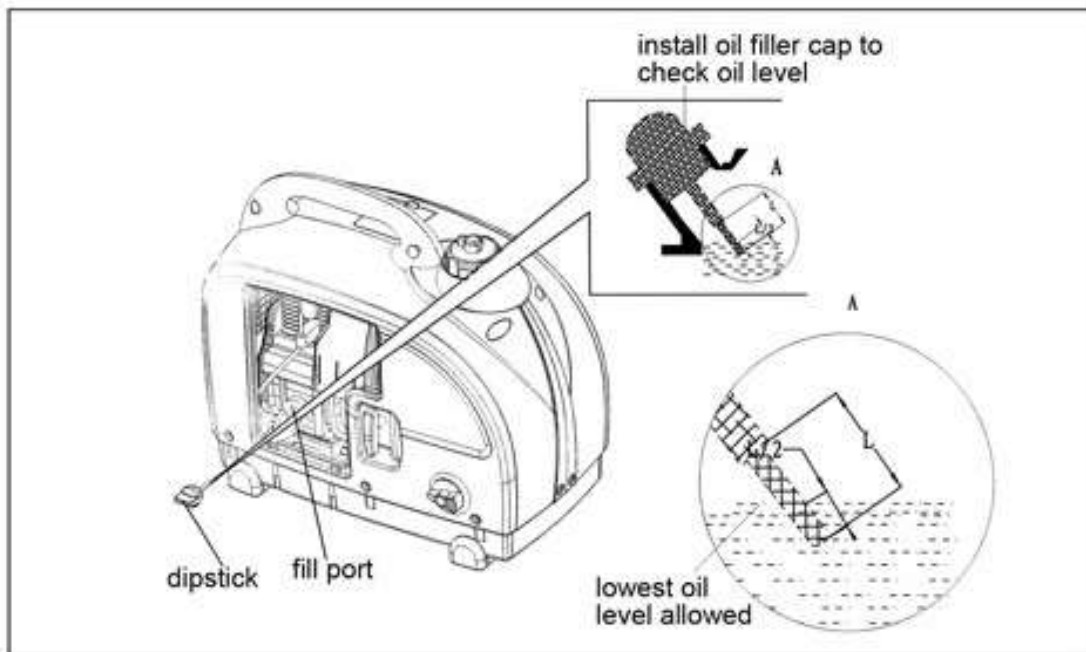

Wash your hands with soap and water after handling used oil

### ⚠ Be careful

- ◆ Dispose of used engine oil in a manner that is compatible with the environment. We suggest you take it in a sealed container to your local service station for reclamation. Do not throw it in the trash or pour it on the ground.

## 2. Air filter service

A dirty air filter will restrict airflow to the carburetor. To prevent carburetor malfunction, service the air filter regularly. Service more frequently when operating the generator in dusty areas.

### ⚠ Warning

- ◆ Do not use fuel or low flash point solvents for cleaning. They are flammable and explosive under certain conditions.

- a. Loosen the cover screw and remove the maintenance cover.
- b. Loosen the screw under the air filter box.
- c. Pull the air filter cover down 30mm according to the (a) and remove the air filter cover according to (b)
- d. Remove the air filter iron clip and check the air filter element. Clean or replace the element if necessary.
- e. Reinstall the air filter parts after cleaning or replacing air filter element.

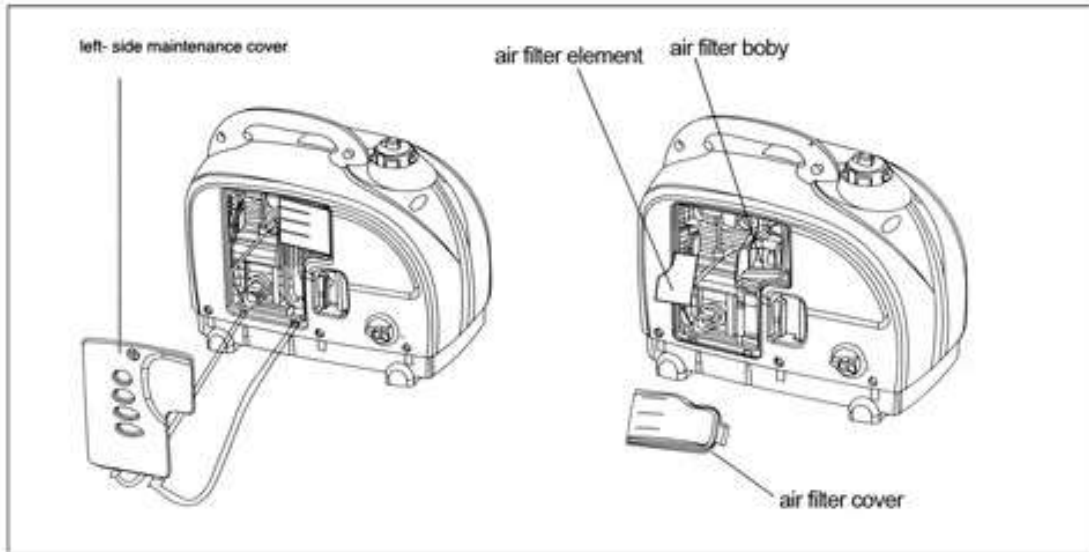

### 3. spark plug servicing

Please use high quality authentic spark plug.

To ensure proper engine operation, the spark plug must be properly gapped and free of deposits.

- (1). Remove the top maintenance cover
- (2). Clean any dirt from around the spark plug base
- (3). Use a spark plug wrench to remove the spark plug.

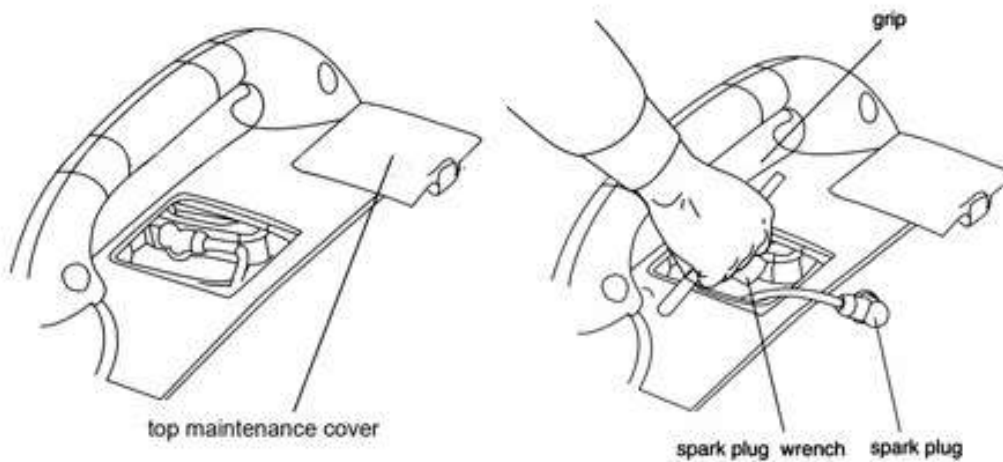

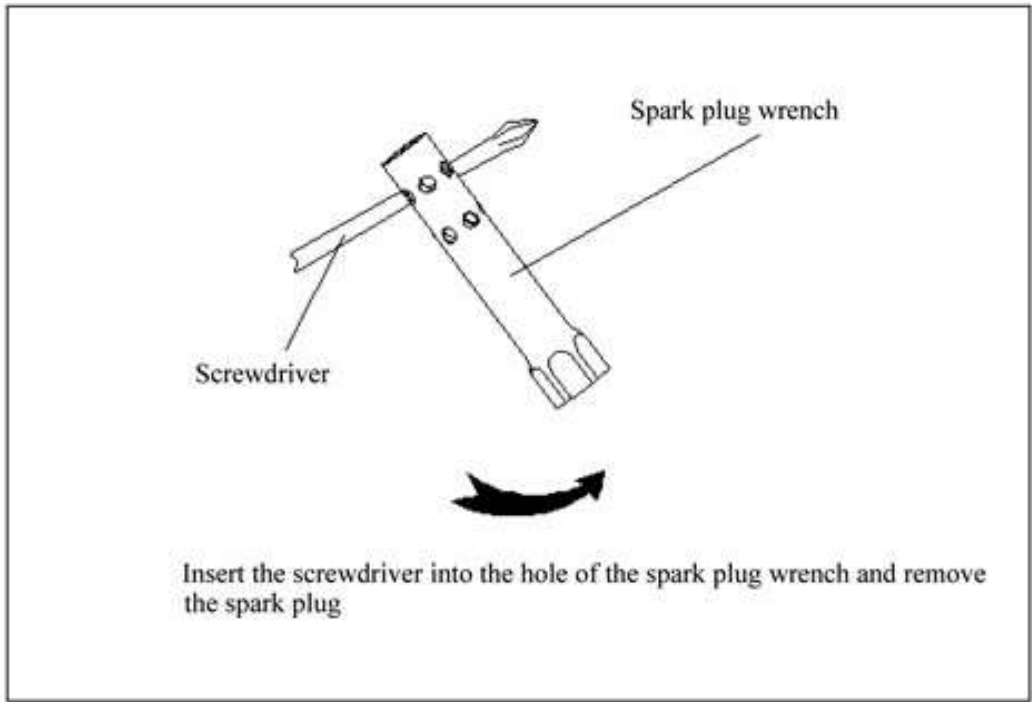

- (4) Visually inspect the spark plug. Discard it if the insulator is cracked or chipped. Clean spark plug with a wire brush if it is to be reused.
- (5) Measure the spark plug gap with plug gauge . It should be 0.6-07mm (0.024-0.028inch)

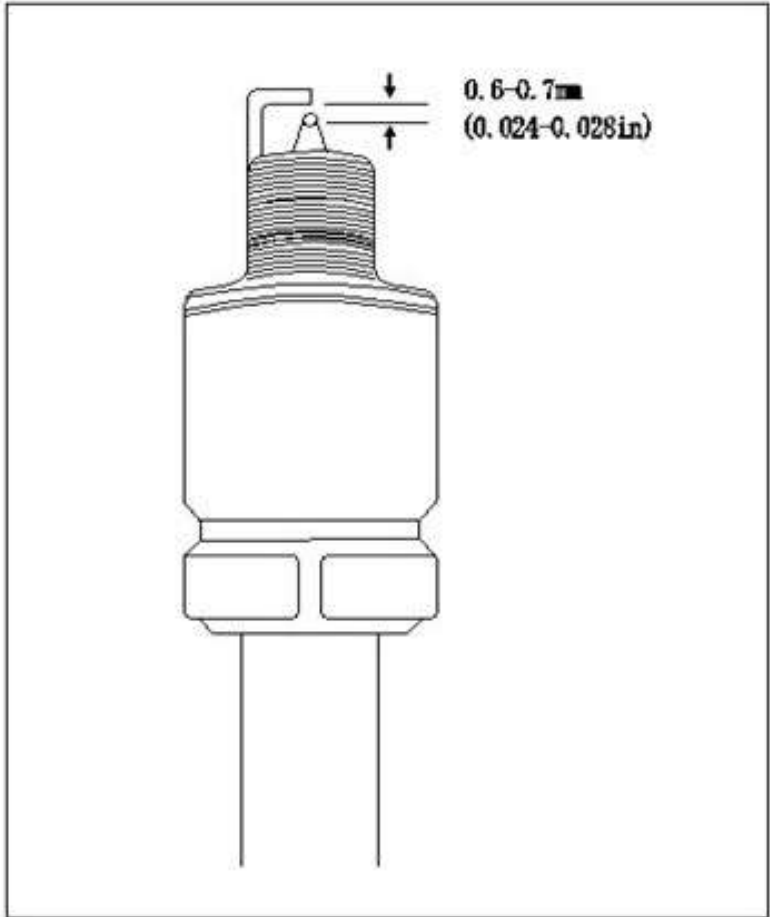

- (6) Install the spark plug carefully by hand, to avoid cross-threading.
- (7) After a new spark plug has been seated by hand, it should be tightened 1/2 turn with a wrench to compress its washer. If a used plug is being reinstalled, it should only require 1/8 to 1/4 turns after being seated.
- (8) Reinstall the spark plug rubber boot on the spark plug securely.
- (9) Reinstall the controlling panel.

### **▲ Be careful**

- ◆ Spark plug must be securely tightened. An improperly tightened plug can become very hot and possibly damage the generator.
- ◆ Never use a spark plug with an improper heat range.
- ◆ Never use a spark plug without damping resistance, or it will cause no AC output

---

## **Transportation and storage**

---

To avoid fuel spillage during transportation and storage, the generator should be secured upright in its normal operation position, with the engine switch OFF. The air vent is turned counterclockwise to the OFF position.

Allow the engine to cool completely before turning the air vent to the OFF position.

### **▲ Warning**

When transporting generator:

- ◆ Do not overfill the tank.(there should be no fuel in the filler neck).
- ◆ Do not operate generators while it is on a vehicle. Take the generator off the vehicle and use it in a well-ventilated place.
- ◆ Avoid direct sunlight when putting the generator in a vehicle, high temperatures inside the vehicle could cause the fuel to vaporize and possibly explode.
- ◆ Do not drive on a rough road for an extended period with the generator on board. If you must transport the generator on a rough road, drain the fuel from the generator beforehand.

Before storing the generator:

- 1) Ensure the storage space is dry and clean
- 2) Drain all fuel in the tank.

### **▲ Warning**

Fuel may become extremely explosive in some conditions. Do not use near open flame or other ignition sources.

1. Completely drain the fuel from the tank. Open the fuel valve, start the engine and operate it in the idle position until all remaining fuel is gone and the engine shuts up automatically.

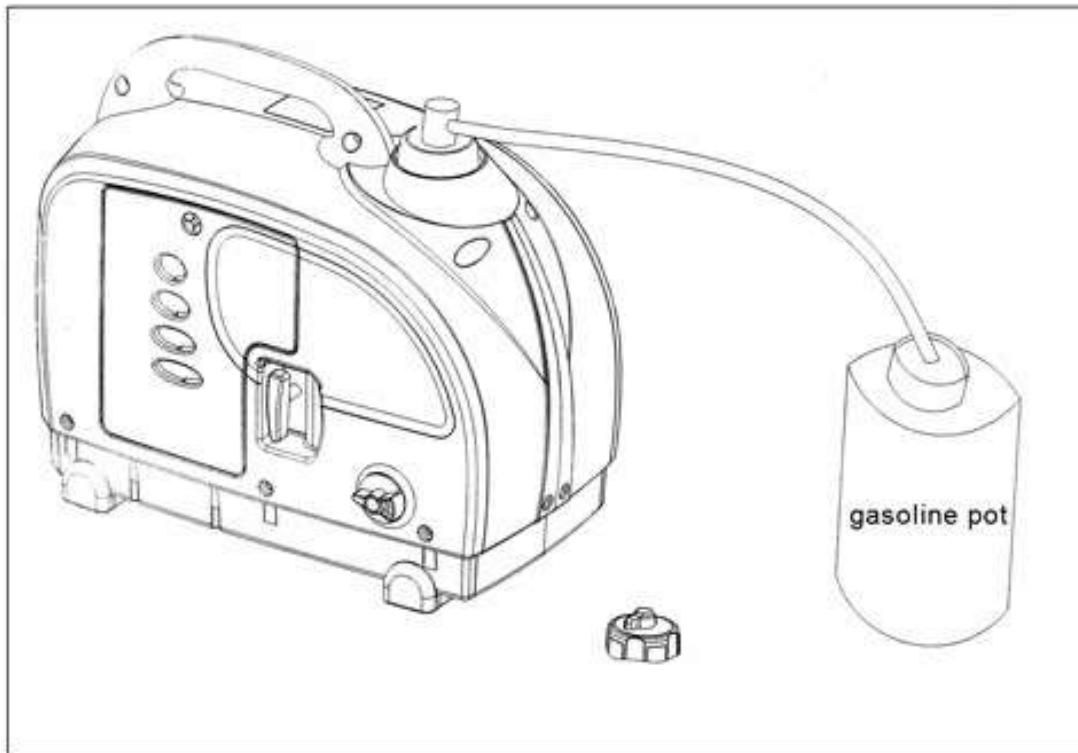

- 2、 Discharge oil.
- 3、 Remove spark plug and Fill cylinder with 2cc's fresh oil. Pull start motor 3-4 times to discharge the remaining oil. Then reinstall the spark plug.
- 4、 Pull the starting cord slowly until resistance is strong. At this time, the piston is moving to the top of the compression stroke, and the valves will be closed.

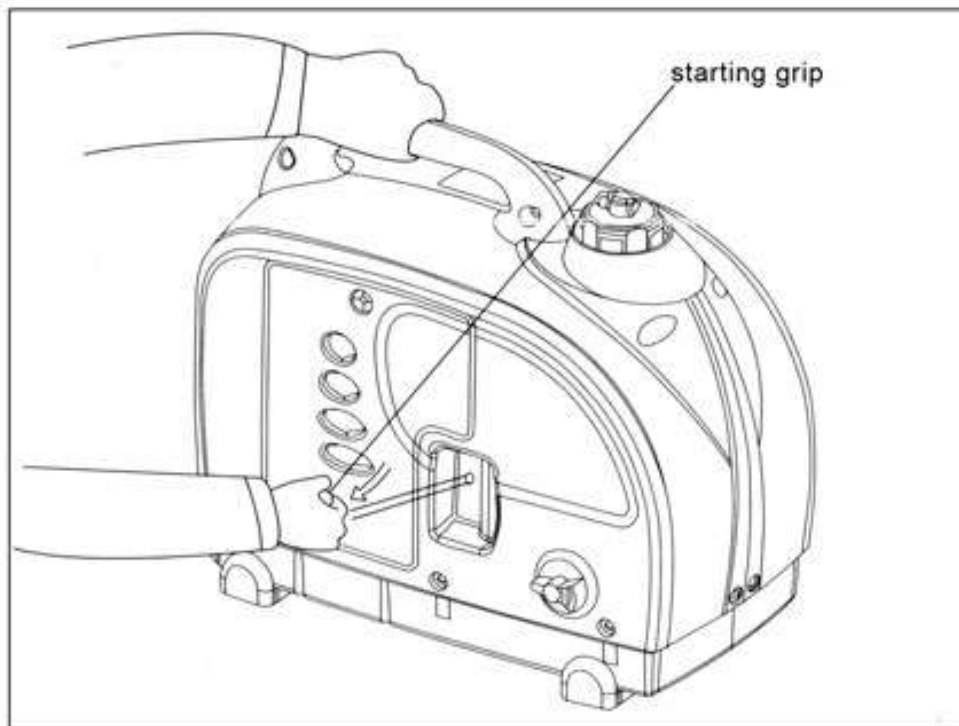



---

## Troubleshooting

---

Engine will not start:

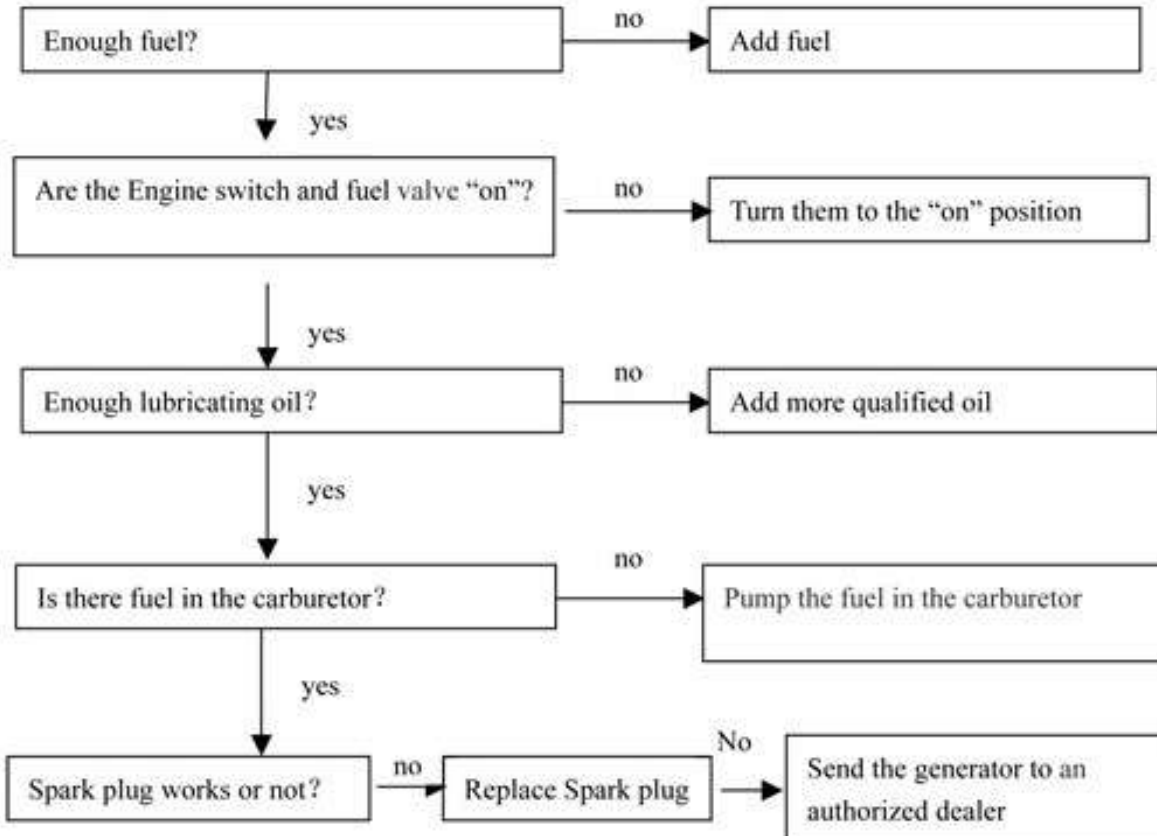

### **▲ Note**

- ◆ Shuck the generator several times to make the float rise if the generator cannot start after adding oil for the first time and the oil alarm indicator stays on when pulling the starting grip.

### **▲ Warning**

- ◆ Make sure there is no spilled fuel around the spark plug. Spilled fuel may ignite.

If the engine still does not start, have the generator repaired by a licensed repair person.

The equipment that connects generator does not start

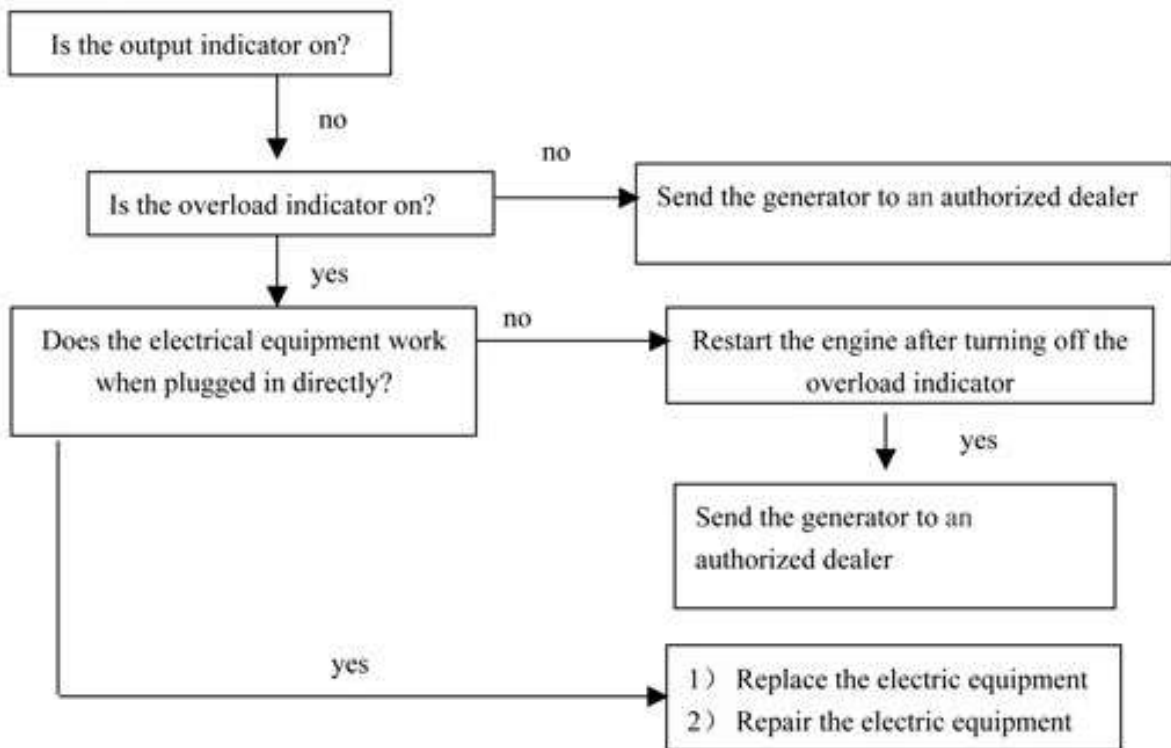

There is no power in the direct current electric outlet:

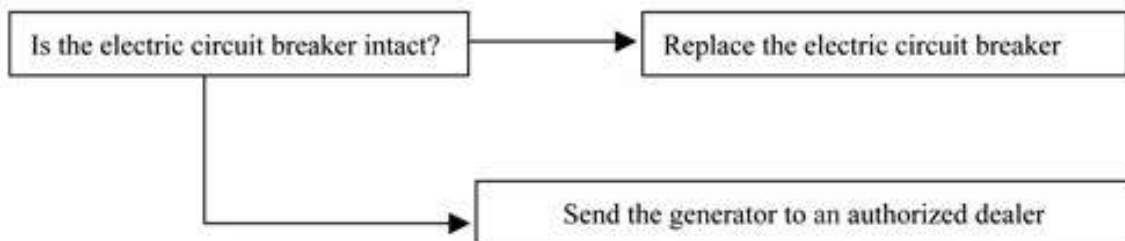

### ★ Deficient AC output

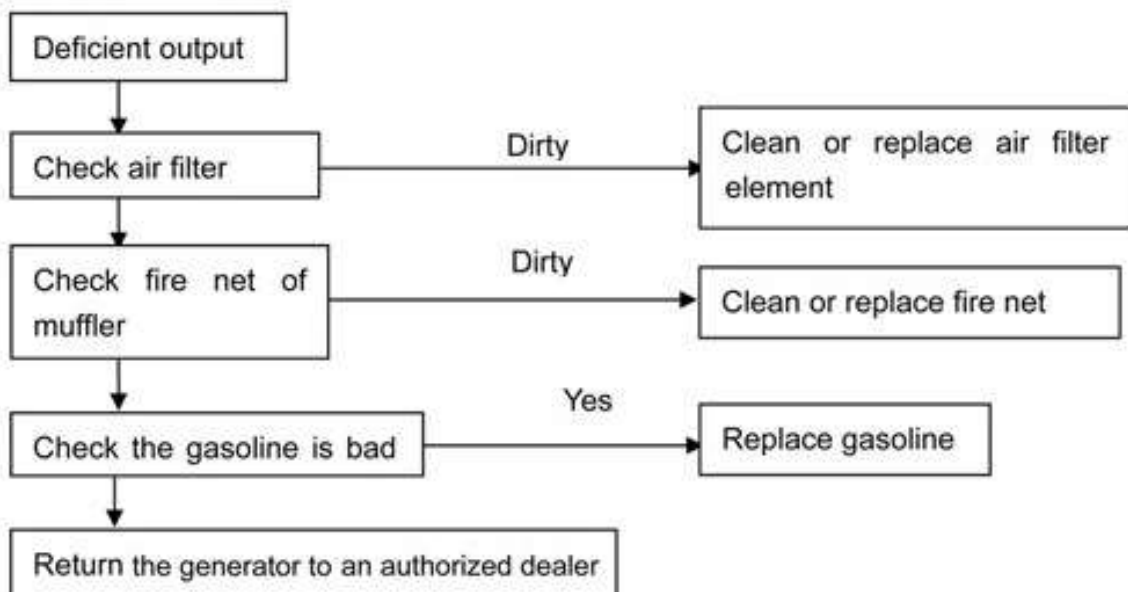

## Specification

### Size and weight

Type	Sinemate 1500
L x W x H (mm)	495×275×415
Net weight (kg)	30 lbs (13.7 kg)

### Engine

Model:	142F
Type	4-stroke OHV 1-Cylinder
Displacement (cc)	50
Compression ratio	7.4
Engine speed	5500rpm (ECO switch is off)
Cooling system	Forced air cooling
Ignition system	TDI
Oil capacity (L)	0.25L
Fuel tank capacity (L)	2.5L
Spark plug	NGK
Noise level (db/7m)	54db

### Generator

Type	Sinemate 1500	
AC output	Rated voltage (V)	100/110/120/220/230/240
	Rated frequency (HZ)	50/60
	Rated output (KVA)	1.0
	Maximum output (KVA)	1.2
DC output	12V/8.3A	For 12V automotive batteries only

# EXPLODED PARTS VIEW

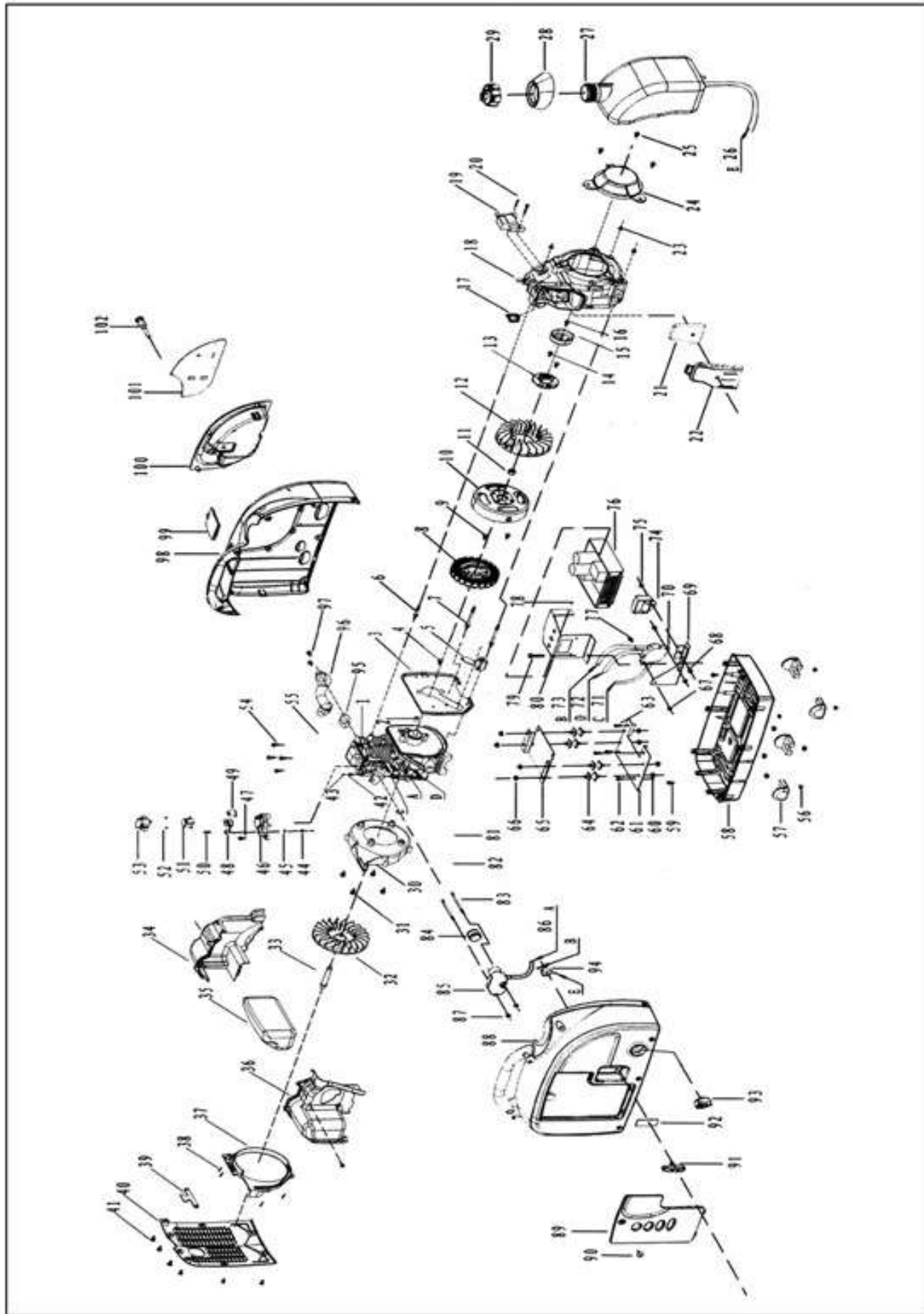

# PARTS LIST

1	Engine	21	Air filter	41	M3 screws	61	Engine holder	81	Left cover	101	Control panel
2	Rear stator housing spacer	22	Air filter cover	42	Cable mount	62	M5 bolts	82	M5 bolts	102	Choke knob assembly
3	Rear stator housing	23	M5 bolts	43	M3 screws	63	M6 screw	83	Stud for carburetor		
4	M5 hex bolt	24	Starter	44	M4 nut	64	Damping legs	84	Filter connection tube		
5	Ignition timing sensor	25	M6 bolts	45	Washer	65	Engine holder	85	Joining pipe		
6	Stud(short)	26	Fuel hose	46	Stepper motor holder	66	M6 nut	86	Breather tube		
7	Stud(long)	27	Fuel tank	47	M4 screw	67	M6 nut	87	M5 nut		
8	Stator assembly	28	Fuel tank cover	48	Throttle adapter	68	M5 nut	88	Left case		
9	M6 hex bolt	29	Fuel cap	49	Preload spring	69	CDI box holder	89	Left maintenance cover		
10	rotor assembly	30	Fan housing	50	M4 screw	70	Vacuum gas pump	90	M6 screw		
11	M10 nut	31	M5 bolts	51	Stepper motor	71	Fuel pump output	91	Starter cord handle		
12	Fan blade	32	Fan	52	M3 screw	72	Vacuum pipe	92	Starter cord base		
13	Clutch	33	Fan blade shaft	53	Stepper motor holder	73	Fuel pump inlet	93	Fuel vavle knob		
14	M6 bolts	34	Cooling air deflector 1	54	M5 bolts	74	CDI box assembly	94	Fuel vavle		
15	Clutch housing	35	Cooling air deflector 2	55	Top cover	75	M5 nut	95	Exhaust manifold gasket		
16	M6 bolts	36	Cooling air deflector 3	56	M5 nut	76	Inverter assembly	96	Exhaust manifold		
17	Small air filter cover	37	Fan cover	57	Pads	77	M5 bolts	97	M5 bolts		
18	Fan blade cover	38	M6 bolts	58	Base	78	M4 screw	98	Right cover		
19	ignition coil	39	Case bracket	59	M5 bolts	79	M5 bolts	99	Top maintenance cover		
20	M5*30 self-taping screw	40	Input air screen	60	M6 nut	80	Indicator holder	100	Control panel base		

## LIMITED WARRANTY

Applicable Products: RAMSOND SINEMATE 1500, 2500, 3500 and 4500 SINEMATE INVERTER GASOLINE GENERATORS.

Ramsond Corporation warrant the above referenced product, to the original purchaser of new equipment, be free from defect or workmanship for a period of one year from the date of purchase, subject to the limitations contained herein. In the event of product failure or malfunction, return the product in person or by courier to:

Ramsond Corporation  
WPC Service Department  
4051 Haggerty Road  
West Bloomfield, Michigan 48323  
Tel: (248) 363-8302 Fax: (248) 363-7834  
email: tech@ramsond.com

You must include the following to receive warranty service:

1. Proof of purchase.
2. Detailed description of the fault or problem
3. Visible Serial Number of the unit
4. \$35 Handling fee (check, money order)
5. Return Shipping Label (prepaid) for returning to you the repaired/replaced product.

The faulty/defective product will then be inspected, repaired or replaced (at our option). The repaired/replaced component/product shall then be returned to the purchaser. The purchaser shall be responsible for all shipping and handling costs of sending the defective/faulty item to us, as well as all shipping and handling costs of returning the repaired/replaced to the customer. Any import/export costs associated with shipping of repaired product outside the United States, such as brokerage fees, taxes, customs or duties are the responsibility of the customer. Certain items which are subject to normal wear and tear are specifically excluded from this warranty (e.g. spark plug, and filters). Please allow up to 30 days from date that we receive the unit for repair/replacement. In the event that we are not able to repair the product, we will replace the product with same or similar unit. In the event that the model is not available, we will replace the machine with an existing model with same or better characteristics, functionality and quality. We reserve the right to replace a defective unit with an identical refurbished unit that has been subjected to testing, which will similarly be warranted against defect or workmanship. Faulty installation, operation or maintenance of the product or attempted repair and maintenance by persons not expressly certified by Ramsond shall render the limited warranty void. Damage resulting from failure to use the product in a manner consistent with our recommendations shall render the limited warranty void. This limited warranty specifically excludes any consequential and/or incidental damages. Although we may provide technical assistance via telephone or email to the customer, it is virtually impossible to troubleshoot all matters via telephone or remote assistance. As such, the offering by us of any technical assistance is made without any warranty or guarantee and provided on "as is" basis. It is the responsibility of each purchaser to determine whether any particular product is compliant with and permissible for use pursuant to the applicable rules, codes and/or regulations, if any, and suitable for particular use and operation. We make no representations or warranties whatsoever concerning the suitability of any merchandise for a particular use or purpose and any such warranty is expressly excluded from the terms of this limited warranty. We reserve the right to make slight modifications necessary to the merchandise for product improvement. This limited warranty shall be subject the laws of the State of Michigan and any claiming arising therefrom shall be interpreted in accordance to the laws of the State of Michigan and subject to the exclusive jurisdiction of the Courts of State of Michigan.

Rev. 08/2011