

RAMSOND®

Digital Inverter Generator

SINEMATE SERIES

SINEMATE 4500



OPERATING INSTRUCTIONS
PLEASE READ THIS MANUAL CAREFULLY
BEFORE USING MACHINE



PREFACE

Thank you for purchasing this Ramsond Sinemate 4500 Generator.

This manual covers operation and maintenance of **SINEMATE 4500**

All information in this publication is based on the latest product information available at the time of approval for printing. We reserve the right to make changes at any time without notice and without incurring any obligation. The copyright of this manual belongs to our company, no part of this publication may be reproduced without written permission.

This manual should be considered a permanent part of the generator and should remain with it if it is resold.

Pay special attention to statements preceded by the following words:

▲ WARNING

It indicates a strong possibility of severe personal injury or death if instructions are not followed.

▲ CAUTION

It indicates a strong possibility of severe personal injury or death if instructions are not followed.

If a problem should arise, or if you have any questions about the generator, consult an authorized dealer.

▲ BE CAREFUL

The generators are designed to give safe and dependable service if operated according to instructions. Read and understand the Owner's Manual before operating the generator. Failure to do so could result in personal injury or equipment damage.

I . Safety Instructions

Warning



- ◆ The generator is designed to give safe and dependable service if operated according to instructions. Read and understand this manual carefully before operating the generator, or it may cause serious injury and equipment damage.

Warning



- ◆ Exhaust contains poisonous carbon monoxide. Do not operate generator in confined area. Be sure to operate the generator in a well-ventilated environment or with an aerator. Using a generator indoors will kill you in minutes. Never use in the home or in a partly enclosed area such as garages. Only use outdoors and far from open windows doors and vents.

Warning



- ◆ The muffler becomes very hot during operating and remains hot for a while after stopping the engine. Be careful not to touch the muffler while it is hot. Let the engine cool before storing the generator indoor.
- ◆ The engine exhaust system will be heated during operation and remain hot immediately after stopping the engine. To prevent scalding, pay more attention to the warning marks attached to the generator.

Be careful



- ◆ Do not parallel connect other cables to receptacles, use special jack, or it may cause an electrical shock.

▲ Warning

- ◆ Gasoline is extremely flammable and is explosive under certain conditions. Refuel in a ventilated area with engine stopped.
- ◆ Keep away from cigarette, smoke and sparks when refueling the generator. Always refuel in a well-ventilated location.

▲ Warning

- ◆ Connection for standby power to a building electrical system must be made by a qualified electrician. The connection must isolate the generator from utility power, and must comply with all applicable laws and electrical codes. Improper connections to a building electrical system can allow electrical current from the generator to backfeed into the utility lines. Such backfeed may electrocute utility company workers or others who contact the lines during a power outage, and the generator may explode, or cause fires when utility power is restored.

▲ Warning

- ◆ To avoid accidents and equipment damage, check generation system every time before starting engine.
- ◆ Keep the generator a distance at least 1 meter from other equipment or other equipment during operation.
- ◆ Keep the generator horizontal when running. If generator tilted, it may cause fuel spillage.
- ◆ Generator operators must be trained, must know how to stop the generator quickly and understand the operation of all controllable parts. Untrained operators should not be allowed to use this equipment.
- ◆ Keep children and pet away from operation area.
- ◆ Keep away from rotating parts during operation.
- ◆ The generator is a potential source of electrical shock when misused. Do not operate it with wet hands or in any wet location.
- ◆ Do not operate the generator in rain or snow and let it get wet.

CONTENT



SINEMATE 4500

1	COMPONENT IDENTIFICATION.....	1
2	SAFETY INSTRUCTIONS.....	2
3	SAFETY LABEL LOCATIONS	3
4	PRE-OPERATION CHECK	3
4.1	<i>Check the engine oil level.....</i>	3
4.2	<i>Check the fuel level.....</i>	5
4.3	<i>Check the air cleaner.....</i>	5
5	GENERATOR USE.....	6
5.1	<i>Starting the engine.....</i>	6
5.2	<i>High altitude operation</i>	8
5.3	<i>Generator use.....</i>	9
5.4	<i>AC applications</i>	9
5.5	<i>Output, Overload and Oil alarm Indicators.....</i>	10
5.6	<i>DC applications</i>	11
5.7	<i>Start the engine</i>	13
5.8	<i>Oil alert system.....</i>	13
5.9	<i>Stopping the engine.....</i>	13
6	MAINTENANCE	15
6.1	<i>Changing oil.....</i>	16
6.2	<i>Air cleaner service.....</i>	18
6.3	<i>Spark plug servicing</i>	18
	<i>Fire net of muffler service.....</i>	20
7	TRANSPORTING AND STORAGE	21
7.1	<i>When transporting generator:.....</i>	22
7.2	<i>Before storing the unit for an extended period:.....</i>	22
8	TROUBLESHOOTING	23
9	SPECIFICATION.....	25
9.1	<i>Size and weight.....</i>	25
9.2	<i>Engine.....</i>	25
9.3	<i>Generator.....</i>	25
10	Wiring diagram.....	26
11	Exploded parts view.....	27
12	Parts list	28

DIGITAL INVERTER GENERATOR 3000W

Warning



Read this manual carefully before using the machine, for your own safety. Your power tool should only be passed on with these instructions.

1 COMPONENT IDENTIFICATION

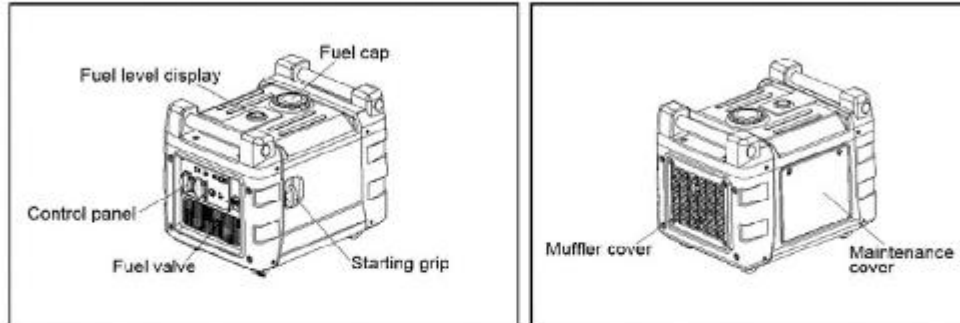

Control panel

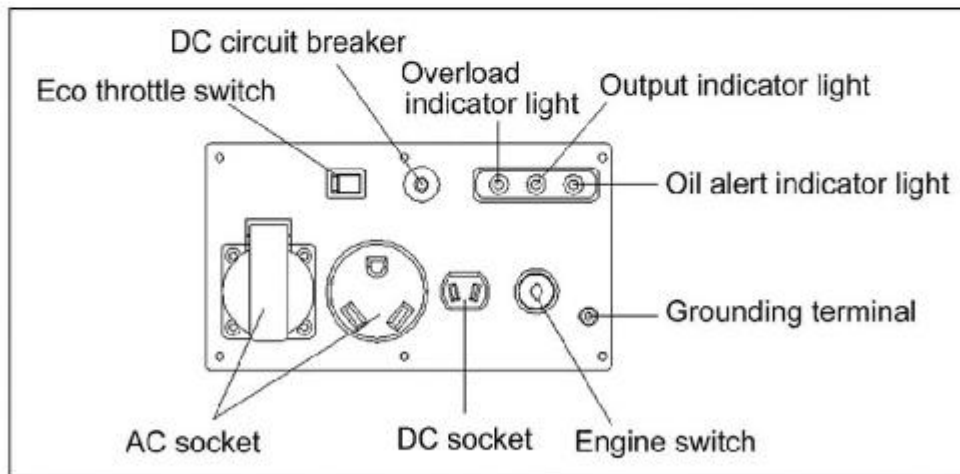

Panels may be different in upgraded models.

Smart Throttle

Engine speed is kept at idle automatically when the electrical appliance is disconnected and it returns to the proper speed to power of the electrical load when electrical appliance is connected. This position is recommended to minimize the fuel consumption while in operation.

Caution

- ◆ Smart throttle system does not operate effectively, if the electrical appliance requires the momentary electric power.
- ◆ When high electrical loads are connected simultaneously, turn the Smart throttle switch to the OFF position to reduce voltage vibration.
- ◆ In DC operation, turn the Smart throttle switch to the OFF position.

2 SAFETY INSTRUCTIONS

- The generator is designed to give safe and dependable service if operated according to instructions.
- Read and understand the Owner's Manual before operating the generator. Failure to do so could result in personal injury or equipment damage.
- Exhaust gas contains poisonous carbon monoxide. Never run the generator in an enclosed area. Be sure to provide adequate ventilation.
- The muffler becomes very hot during operation and remains hot for a while after stopping the engine. Be careful not to touch the muffler while it is hot. Let the engine cool before storing the generator indoors.
- The engine exhaust system will be heated during operation and remain hot immediately after stopping the engine. To prevent scalding, pay attention to the warning marks.
- Gasoline is extremely flammable and explosive under certain conditions. Refuel in a well ventilated area with the engine stopped.
- Keep away from cigarette, smoke and sparks when re-fuelling the generator, Always refuel in a well ventilated location.
- Wipe up spilled gasoline at once.
- Connections for standby power to a building's electrical system must be made by a qualified electrician and must comply with all applicable laws and electrical codes. Improper connections can allow electrical current from the generator to back feed into the utility lines. Such back feed may electrocute utility company workers or others who contact the lines during a power outage, and when utility power is restored, the generator may explode, burn, or cause fires in the building's electrical system.
- Always make a pre-operation inspection before you start the engine. You may prevent an accident or equipment damage.
- Place the generator at least 1m (3ft) away from buildings or other equipment during operation.
- Operate the generator on a level surface. If the generator is tilted, fuel spillage may result.
- Know how to stop the generator quickly and understand operation of all the controls. Never permit anyone to operate the generator without proper instructions.
- Keep children and pets away from the generator when it is in operation.
- Keep away from rotating parts while the generator is running.
- The generator is a potential source of electrical shocks when misused; do not operate with wet hands.
- Do not operate the generator in rain or snow and do not let it get wet.

3 SAFETY LABEL LOCATIONS

These labels warn you for potential hazards that can cause serious injury. Read the labels and safety notes and precautions described in the manual carefully. If a label comes off or becomes hard to read, contact your dealer for a replacement.

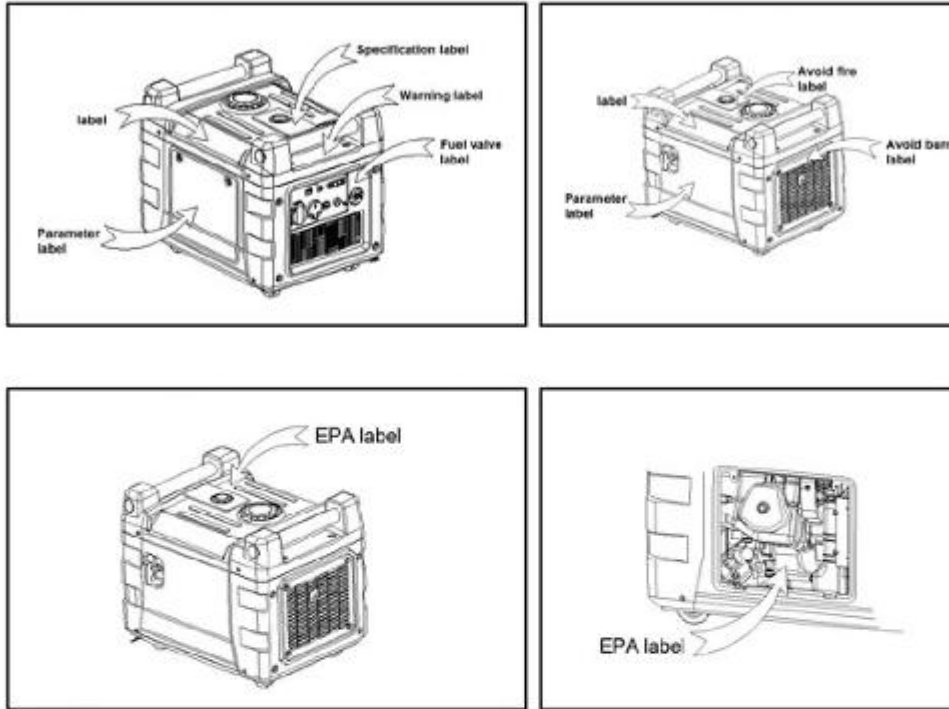

4 PRE-OPERATION CHECK



Be sure to check the generator on a level surface with the engine stopped and the brake of the wheels be tightened.

Make sure no sundries around the generator, and make the generator insulate from other buildings or equipment at least 1 metre. Tighten the brake of wheels before start the generator.

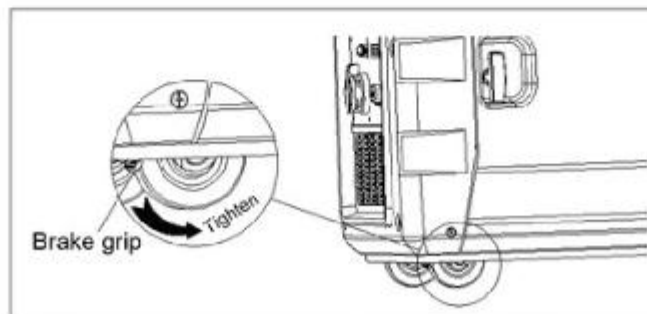

4.1 Check the engine oil level.



Using non-detergent oil or 2-stroke engine oil could shorten the engine's service life.

Use high-detergent, premium quality 4-stroke engine oil, certified to meet or exceed U.S. automobile manufacturer's requirements for API Service Classification SG, SF, (15W40) Select the appropriate viscosity for the average temperature in your area

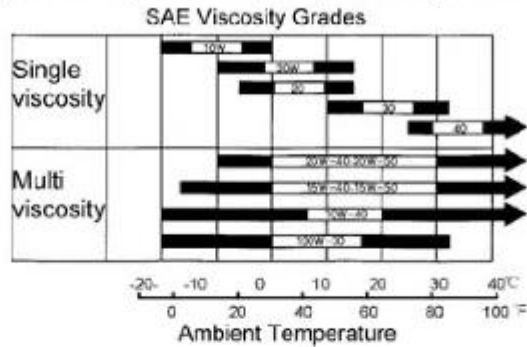

Loosen the cover screw and remove the left side maintenance cover. Remove the oil filler cap, and wipe the dipstick with a clean rag. Check the oil level by inserting the dipstick in the filler hole without screwing it in.

If the oil level is below the end of the dipstick, refill the recommended oil up to the top of the oil filler neck.



The Oil Alert System will automatically stop the engine before the oil level falls below the safe limit. However, to avoid the inconvenience of an unexpected shutdown, it is still advisable to visually inspect the oil level regularly.

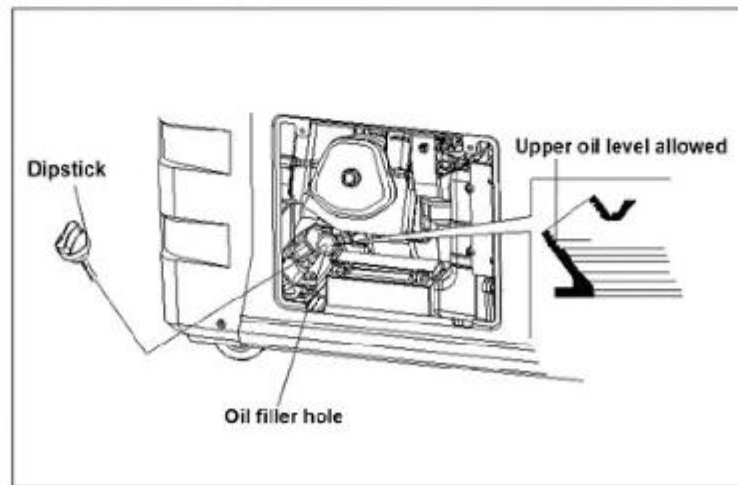



4.2 Check the fuel level.

- Tighten the fuel filler cap before transporting.
- Check the fuel level display carefully, refill fuel to the standard level when the red pointer point to "E" position.
- Use automotive fuel (Unleaded or low leaded is preferred to minimize combustion chamber deposits).
- !! Don't use fuel containing alcohol: Fuel system damage or engine performance problems resulting from the use of fuels that contain alcohol are not covered under the warranty.
- Never use an oil/gasoline mixture or dirty gasoline.
- Avoid getting dirt, dust or water in the fuel tank.
- After refuelling, tighten the fuel filler cap securely.

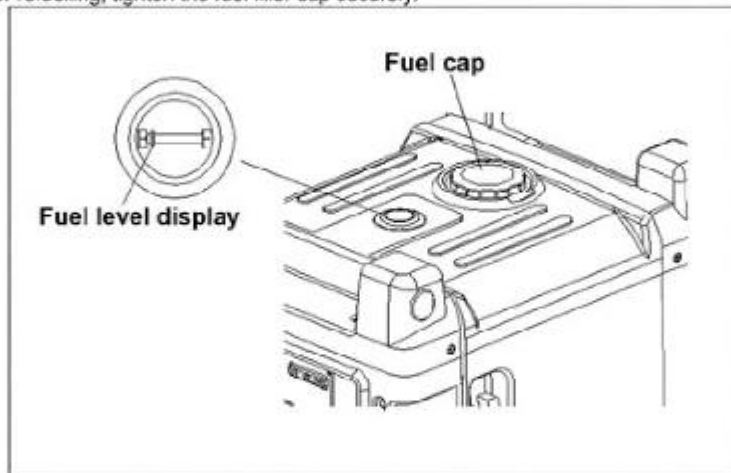

- Gasoline is extremely flammable and is explosive under certain conditions.
- Refuel in a well-ventilated area with the engine stopped.
- Do not smoke or allow flames or sparks in the area where the engine is refuelled or where gasoline is stored.
- Do not overfill the fuel tank. After refuelling, make sure the tank cap is closed properly and securely.
- Be careful not to spill fuel when refuelling. Spilled fuel or fuel vapour may ignite. If any fuel is spilled, make sure the area is dry before starting the engine.
- Avoid repeated or prolonged contact with skin or breathing of vapour. KEEP OUT OF REACH OF CHILDREN

4.3 Check the air cleaner.

Check the air cleaner element to be sure it is clean and in good condition.

1. Loosen the cover screw and remove the left side maintenance cover.
2. Press the latch tab on the top of the air cleaner body, remove the air cleaner cartridge, and check the element.
3. Clean or replace the element if necessary.

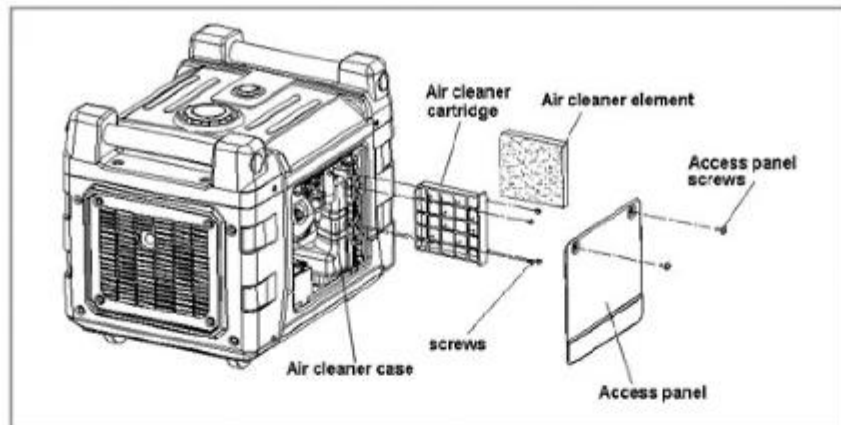

Never run the engine without the air cleaner. Rapid engine wear will result from contaminants, such as dust and dirt, being drawn through the carburettor, into the engine.

It is normal for a little oil to appear under the air filter box if the generator is running for a long period of time, or a lot of oil is in the engine. Wipe up excess oil after each use and after stopping the generator.

5 GENERATOR USE

5.1 Starting the engine



Before starting the engine, disconnect any load from the DC receptacle.

Electric starter

1. Turn the fuel valve to the ON position.

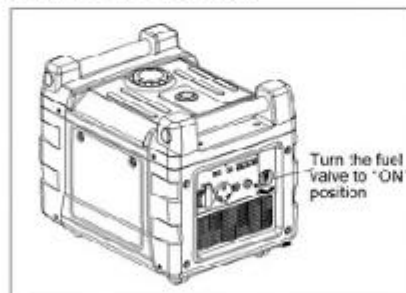

2. Put the electric start key into the engine engine switch, and turn it to "ON" position.

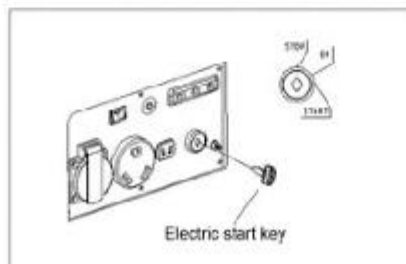

3. Turn the electric start key to "START" position by deasil direction until the engine has started.

Careful

The first time to start the engine, or restart the engine after long time by electric starter, if the engine can't be started (Maybe the battery is lack of electric energy), PLS use the recoil starter to start the engine.

Using recoil starter to start the engine

1. Turn the fuel valve to "ON" position.



2. Put the electric start key into engine switch, and turn it to "ON" position.

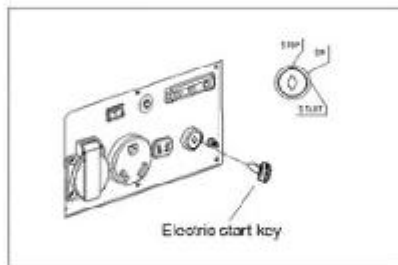

3. Pull the starting grip lightly until resistance is felt, then pull briskly to start the engine.

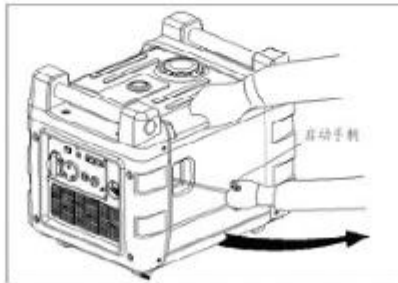

⚠ Be careful

- ◆ Never allow the starter grip to snap back, return it slowly by hand.
- ◆ Grasp the carrying handle firmly to prevent the generator from falling over when pulling the starting grip.



If the engine stops and will not restart, check the engine oil level before troubleshooting in other areas.

5.2 *High altitude operation*

At high altitude, the standard carburettor air-fuel mixture will be excessively rich. Performance will decrease, and fuel consumption will increase.

High altitude performance can be improved by installing a smaller diameter main fuel jet in the carburettor and readjusting the slow tempo screws. If you always operate the generator at altitudes higher than 1,500 m (5,000 feet) above sea level, have your dealer perform these carburettor modifications.

Even with suitable carburettor jetting, engine horsepower will decrease approximately 3.5% for each 300m (1,000 feet) increase in altitude. The effect of altitude on the horsepower will be greater than this if no carburettor modification is made.



Operation of the generator at an altitude lower than the carburetor is jetted for may result in reduced performance, overheating, and serious engine damage caused by an excessively lean air/fuel mixture.

5.3 Generator use

5.3.1 Warning!

- To prevent electrical shock from faulty appliances, the generator should be grounded. Connect an electric conductor (cable) of at least 1.5mm² between the generator's ground terminal and an external ground source.
- Connections for standby power to a building's electrical system must be made by a qualified electrician and must comply with all applicable laws and electrical codes. Improper connections can allow electrical current from the generator to back feed into the utility lines. Such back feed may electrocute utility company workers or others who contact the lines during a power outage, and when utility power is restored, the generator may explode, burn, or cause fires in the building's electrical system.
- Limit operation requiring maximum power to 30 minutes. For continuous operation, do not exceed the rated power. In either case, the total wattage of all appliances connected must be considered.
- Do not exceed the current limit specified for any one receptacle.
- Do not connect the generator to a household circuit. This could cause the damage to the generator or to electrical appliances in the house.
- Do not modify or use the generator for other purpose than it is intended for. Also observe the following when using the generator.
 - Do not connect generators in parallel.
 - Do not connect an extension to exhaust pipe.
- When an extension cable is required, be sure to use a rubber sheathed flexible cable.
- Limit length of extension cables: 60m for cables of 2 mm² and 100m for cables of 4mm².
- Keep the generator away from other electric cables or wires such as distribution network.
- The DC receptacle can be used while the AC power is in use. If you use both at the same time, be sure not to exceed the total power for AC and DC.
- Most appliance motors require more than their rated wattage for start-up.

5.4 AC applications

1. Start the engine and make sure the output indicator light (green) illuminates.
2. Confirm that the appliance to be used is switched off, and plug in the appliance.

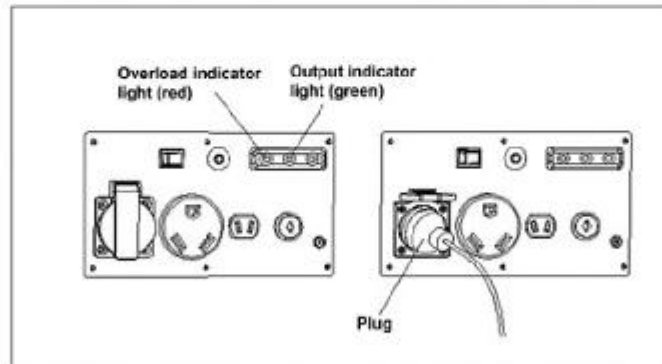

- Substantial overloading that continuously lights the overload indicator light (red) may damage the generator. Marginal overloading that temporarily lights the overload indicator light (red) may shorten the service life of the generator.
- Be sure that all appliances are in good working order before connecting them to the generator. If an appliance begins to operate abnormally, becomes sluggish, or stops suddenly, turn off the generator engine switch immediately. Then disconnect the appliance, and examine it for signs of malfunction.

5.5 Output, Overload and oil alarm indicator.

- The output indicator light (green) will remain lighted during normal operating conditions.
- If the generator is overloaded or if there is a short in the connected appliance, the output indicator light (green) will go OFF, the overload indicator light (red) will go ON and current to the connected appliance will be shut off.
- Stop the engine if the overload indicator light (red) switches ON and investigate the overload source.
- Stop the engine if the oil alarm indicator light (red), PLS check the oil level, refill oil or not.



Before connecting an appliance to the generator, check that it is in good order, and that its electrical rating does not exceed that of the generator. Then connect the power cord of the appliance, and start the engine.

Be sure all equipment is turned off before plugging in the power cord.

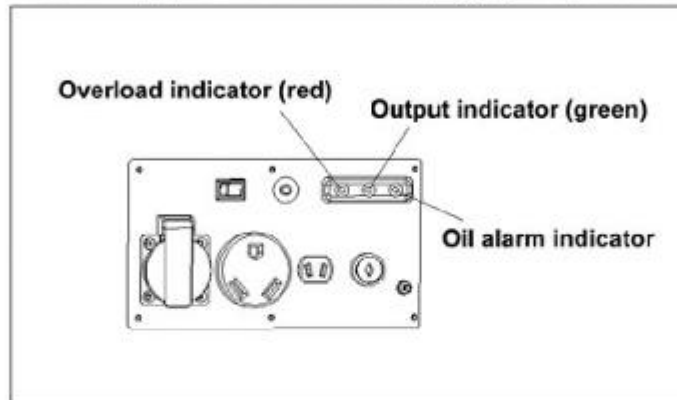

- When an electric motor is started, both the overload indicator light (red) and the output indicator light (green) may go on simultaneously. This is normal if the overload indicator light (red) goes off after about four seconds.
 - If the overload indicator light (red) stays on, **consult your dealer**.
1. Connect the ground terminal

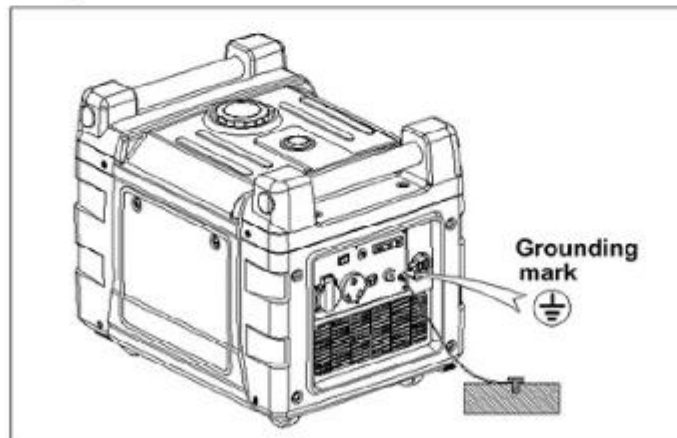

2. Start engine according to "STARTING THE ENGINE".



When the output indicator light (green) does not light and the overload indicator light (red) lights instead, set the engine switch to STOP, stop the engine at once and then start the engine again.

3. Confirm that the equipment to be used is switched off, and insert the plug of the equipment to be used into the AC receptacle unit A.



Check that the equipment to be connected is switch off. When the equipment to be used is switched on, it will operate suddenly, and injuries or accidents may be caused.

4. Switch on the equipment output indicator light will glitter (light). In case of overload operation or when trouble occurs for the equipment being used, the output indicator light (green) will go out, the overload indicator light (red) will light continuously, and no power will be put out. At this time, the engine will not stop, so that the engine must be stopped by setting the respective engine switch to STOP.

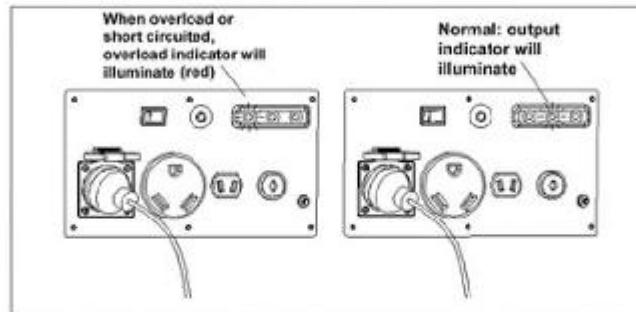

When equipment requires a large starting power, the overload indicator lights (red) and the output indicator light (green) may light together for a short time, but this is no abnormality. After start of the equipment, the overload indicator light (red) will go out and the output indicator light (green) will stay lit.

5.6 DC applications

For charging 12V automotive batteries:

	Idling voltage (V)	Loading voltage (V)	Loading current (A)
Opening the smart throttle	22	12	6
Closing the smart throttle	27	13	8.5
DC Max. output power	37	13.5	8.5

The generator cannot sense a sensibility load with the same power which the manual indicates. It only can sense 40%-70% power which the manual indicates.

- When using the DC output, turn Smart Throttle to the OFF position. The DC current will be below 5A if turning on the Smart Throttle without AC current output.
- When charging batteries, person must be present to monitor the voltage. Stop charging when the voltage of the batteries is above 16V. Or it may cause battery explosion, resulting in serious injury or death.

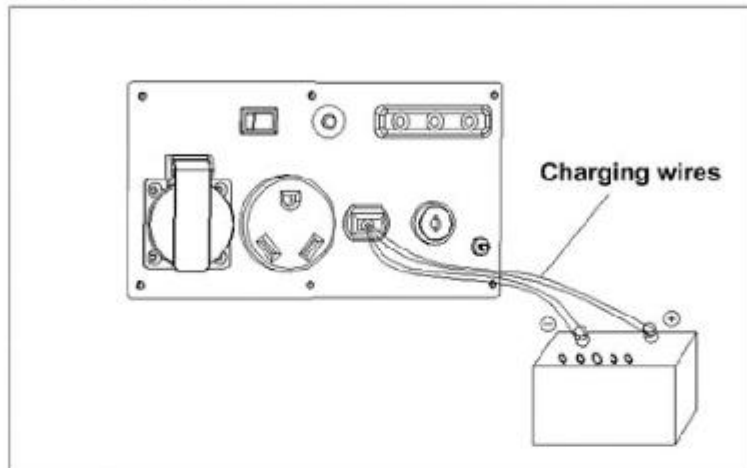

- To prevent the possibility of creating a spark near the battery, connect charging cable first to the generator, then to the battery. Disconnect cable first at the battery.
- Before connecting charging cables to a battery that is installed in a vehicle, disconnect the vehicle's grounded battery cable. Reconnect the vehicle's grounded battery cable after the charging cables are removed. This procedure will prevent the possibility of a short circuit and sparks if you make accidental contact between a battery terminal and the vehicle's frame or body.
- Do not attempt to start an automobile engine while the generator still connected to the battery. The generator may be damaged.
- Connect the positive battery terminal to the positive charging cord. Do not re-verse the charging cables, or serious damage to the generator and/or the battery may occur.
- The battery gives off explosive gases; keep spark, flames and cigarettes away. Provide adequate ventilation when charging.
- The battery contains sulphuric acid (electrolyte). Contact with skin or eyes may cause severe burns. Wear protective clothing and a face shield.
 - If electrolyte gets on your skin, flush with water.
 - If electrolyte gets in your eyes, flush with water for at least 15 minutes and call a physician.
- Electrolyte is poisonous.
 - If swallowed, drink large quantities of water or milk and follow with milk or magnesia or vegetable oil and call a physician.
- **KEEP OUT OF THE REACH OF CHILDREN, PETS AND UNTRAINED PEOPLE.**

5.7 Start the engine

- The DC receptacle may be used while the AC power is in use.
- An overloaded DC circuit will trip the DC circuit protector. If this happens, disboard the DC load before pushing in the circuit protector to resume operation.

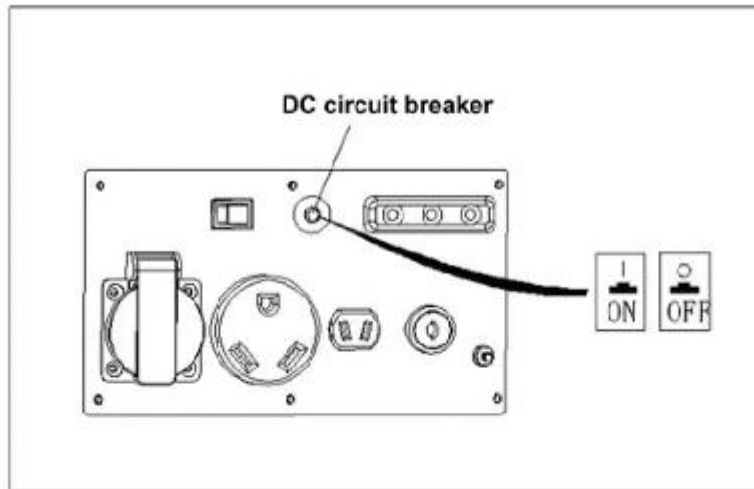

5.8 Oil alert system

- The oil alert system is designed to prevent engine damage caused by an insufficient amount of oil in the crankcase. Before the oil level in the crankcase falls below a safe limit, the oil alert system will automatically shut down the engine (the engine switch will remain in the ON position).
- If the oil alert system shuts down the engine, the oil alert indicator light (red) will come on when you operate the starter, and the engine will not run. If this occurs, add engine oil.

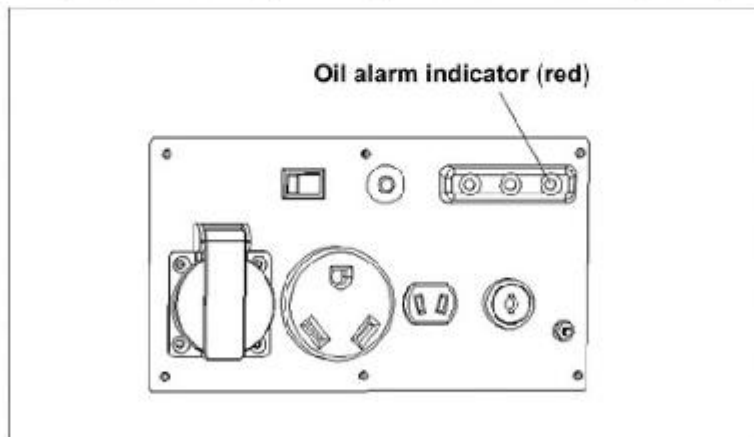

5.9 Stopping the engine

To stop the engine in an emergency, turn the engine switch to the OFF position.

In normal use:

1. Switch off the connected equipment and pull the inserted plug out.

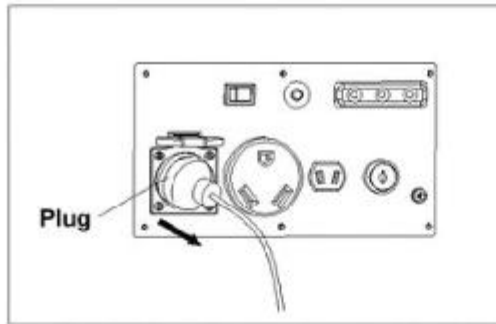

2. Turn the electric start key to the OFF position, and take out the key.

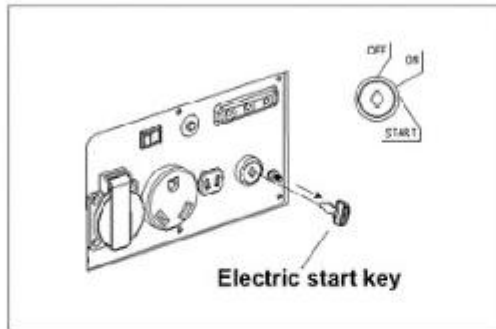

3. Turn the fuel valve to the "OFF" position.

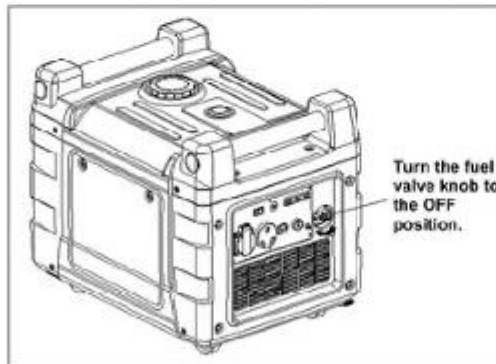

 Be sure to tighten the fuel cap and the engine switch is in "OFF" position when stopping, transporting and/or storing the generator.

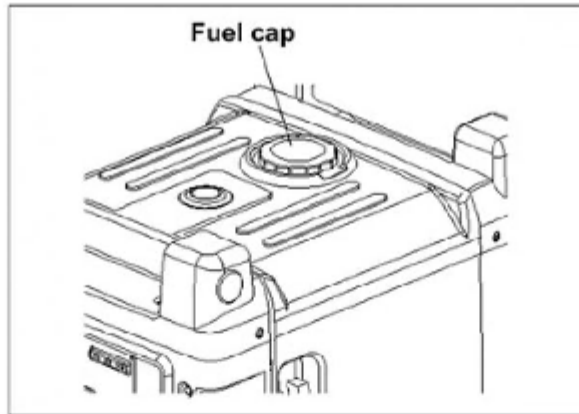

6 MAINTENANCE

- The purpose of the maintenance and adjustment schedule is to keep the generator in the best operating condition.
- Inspect or service as scheduled in the table below.



Shut off the engine before performing any maintenance. If the engine must be run, make sure the area is well ventilated. The exhaust contains poisonous carbon monoxide gas.



Use authorized parts or their equivalent. The use of replacement parts which are not of equivalent quality may damage the generator.

Maintenance Schedule

REGULAR SERVICE PERIOD(1)						
ITEM Perform at every indicated month or operating hour interval, whichever comes first.		EACH USE	FIRST MONTH OR 20HRS	EVERY 3 MONTHS OR 50HRS	EVERY 6 MONTHS OR 100 HRS	EVERY YEAR OR 200 HRS
Engine oil	Check level	●				
	Change		●		●	
Air cleaner	Check			●		
	Clean			●(2)		
Spark plug	Check-adjust				●	
Spark arrester	Clean				●	
Valve clearance	Check-adjust					●(3)
Fuel tank and filter	Clean					●(3)
Fuel line	Check	Every 2 years (Replace if necessary) (3)				

NOTE:

- (1) Log hours of operation to determine proper maintenance.
 (2) Service more frequently when used in dusty areas.
 (3) These items should be serviced by an authorized dealer, unless the owner has the proper tools and is mechanically proficient. See the Shop Manual.

Temperature (C°)	Time for changing oil (hour)	Recommended power factor
25	Normal	100%
30	18	95%
35	15	85%
40	12	70%

6.1 Changing oil

Drain the oil while the engine is still warm to assure rapid and complete draining.



Make sure to turn the engine switch and the fuel cap vent lever OFF before draining.

1. Remove the screws and open the access panel.
2. Take out the battery.
3. Remove the jetting oil bolt, and spill out the oil.

Engine oil capacity: 1.0L

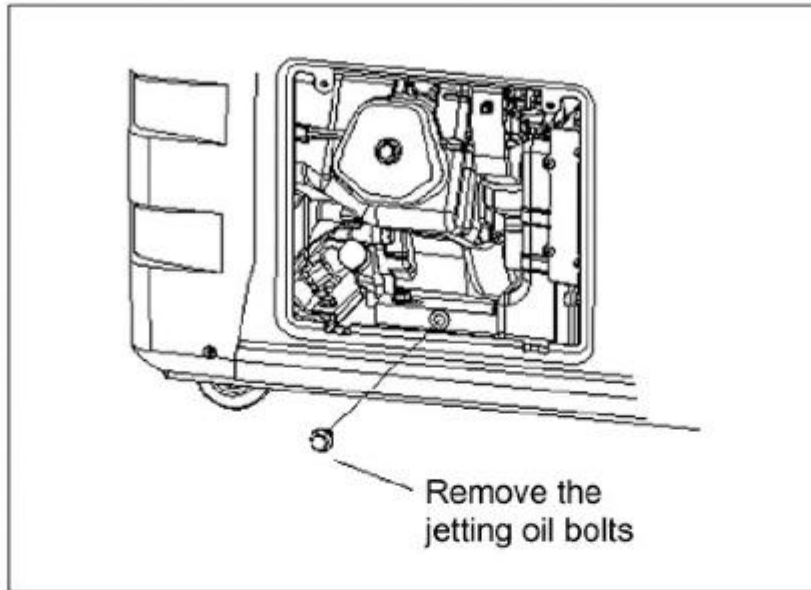

Refill oil

1. Remove the screws and open the access panel.
2. Revolve out the dipstick.
3. Revolve the oil filling pipe into the oil filler hole.
4. Use the oil filling bottle pour the oil into the crankcase and check the oil level.

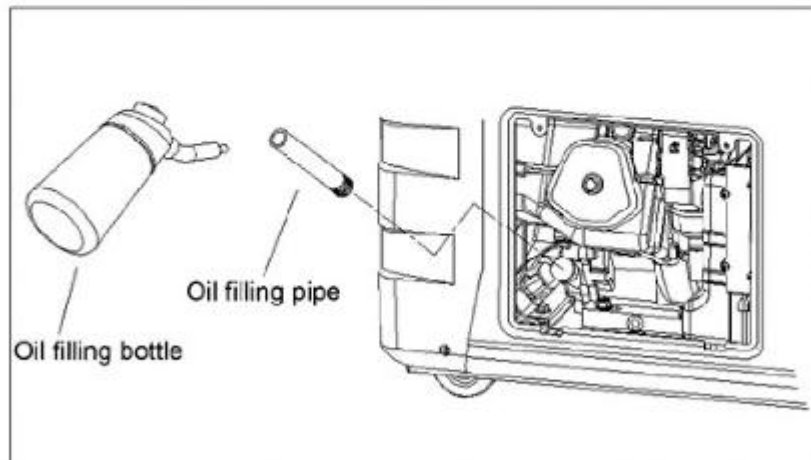

After refill the new oil into the crank case, PLS shake the generator left to right some times and make sure the bobber of the oil alarm system is floating.

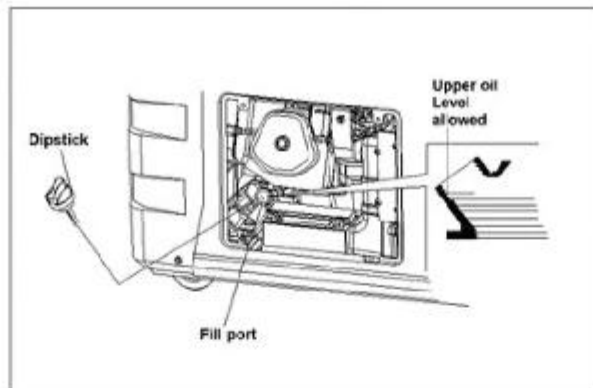

Wash your hands with soap and water after handling used oil.



Please dispose of used motor oil in a manner that is compatible with the environment. We suggest you take it in a sealed container to your local service station for reclamation. Do not throw it in the trash or pour it on the ground.

6.2 Air cleaner service

A dirty air cleaner will restrict air flow to the carburettor. To prevent carburettor malfunction, service the air cleaner regularly. Service more frequently when operating the generator in extremely dirty areas.



Do not use gasoline or low flash point solvents for cleaning. They are flammable and explosive under certain conditions.

1. Loosen the access panel screw and remove the access panel.
2. Remove the 4 screws under the air filter case.
3. Pull the air filter cartridge down 30mm and remove the air filter cartridge.
4. Remove the air filter iron clip and check the air filter element. Clean or replace the element if necessary.
5. Reinstall the air filter parts after cleaning or replacing air filter element.

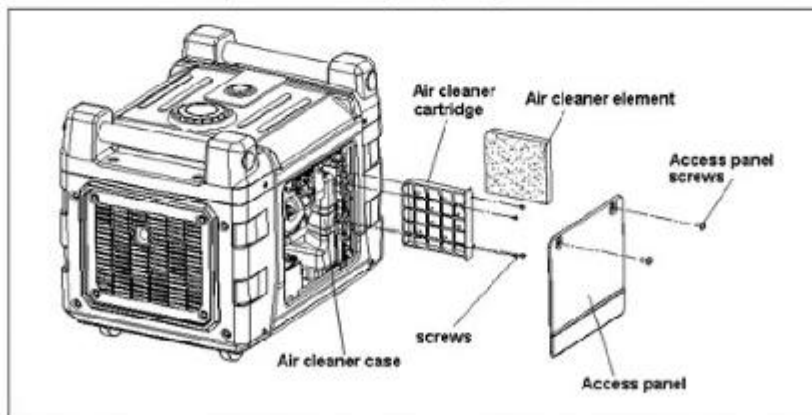

6.3 Spark plug servicing

Please use high quality authentic spark plug (NGK). To ensure proper engine operation, the spark plug must be properly gapped and free of deposits.

1. Remove the screws on top maintenance cover and the cover.

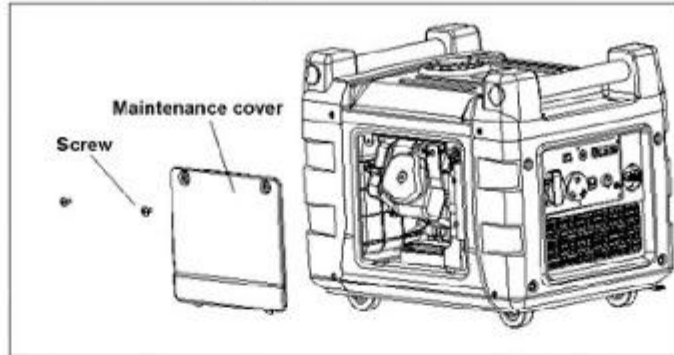

2. Take out the ignition coil rubber boot.

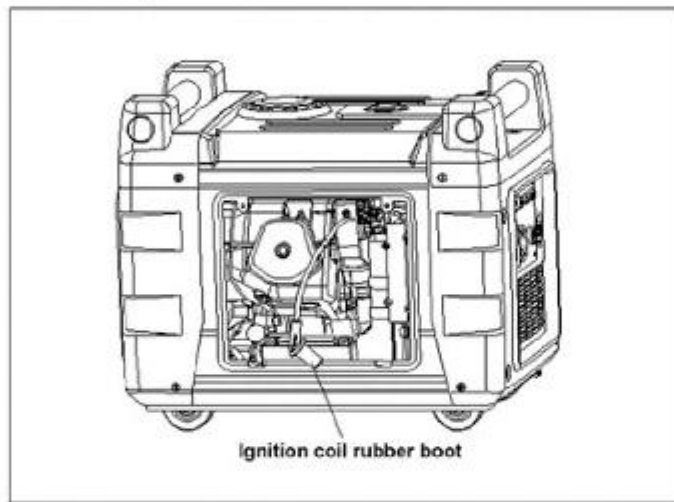

3. Remove the spark plug with spark plug wrench.

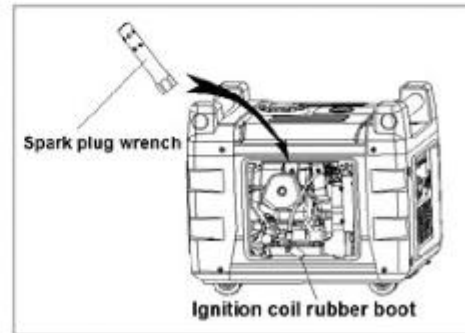
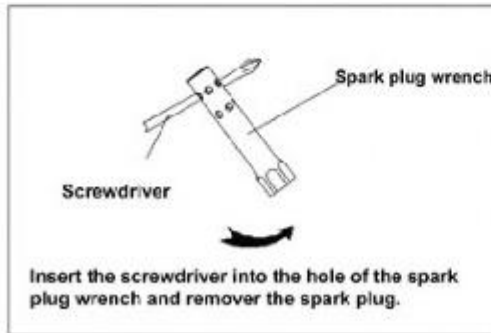

4. Visually inspect the spark plug. Discard it if the insulator is cracked or chipped. Clean spark plug with a wire brush if it is to be reused.

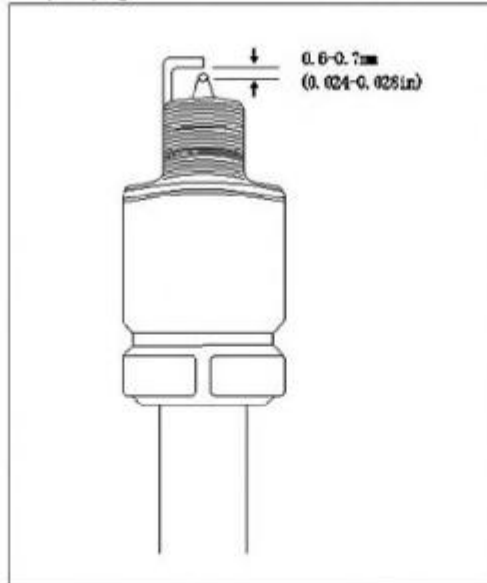

5. Install the spark plug carefully by hand, to avoid cross-threading.
6. After a new spark plug has been seated by hand, it should be tightened $\frac{1}{8}$ turn with a wrench to compress its washer. If a used plug is being reinstalled, it should only require $\frac{1}{8}$ to $\frac{1}{4}$ turns after being seated.
7. Reinstall the ignition coil rubber boot on the spark plug securely.
8. Reinstall the controlling panel.



- The spark plug must be securely tightened. An improperly tightened plug can become very hot and possibly damage the generator.
- Never use a spark plug with an improper heat range.
- Never use a spark plug without damping resistance, or it will cause no AC output.
- output.

Fire net of muffler service

Uncleaned muffler will make big noise and affect the engine's running.

Clean and maintenance the fire net timely, make sure the generator works normally.

The fire net of muffler needs cleaning frequently if you use the generator in very dirty conditions, or replace the fire net if necessary.

▲ Careful

- ◆ Before clean the fire net of muffler make sure the generator stop working.
- ◆ Before check and maintenance the fire net of muffler, make sure the machine is cooling, otherwise, it will cause scald by the hot muffler.

1. Remove the M6 screws and open the muffler cover.
2. Remove two M4 screws on the fire net.
3. Take down the fire net as per the following figure.
4. Check the fire net, clean or replace it if necessary.

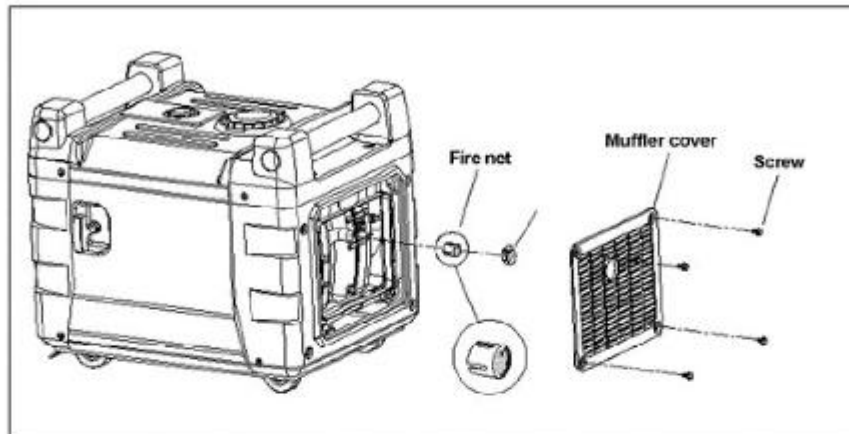

7 TRANSPORTING AND STORAGE

To prevent fuel spillage when transporting or during temporary storage, the generator should be secured upright in its normal operating position, with the engine switch OFF. The fuel cap vent lever is turned counter clockwise to the OFF position. Allow the engine to cool well before turning the fuel cap vent lever to the OFF position.

7.1 When transporting generator:

- Do not overfill the tank. (there should be no fuel in the filler neck)
- Do not operate the generator while it is on a vehicle. Take the generator off the vehicle and use it in a well ventilated place.
- Avoid a place exposed to direct sunlight when putting the generator on a vehicle. If the generator is left in an enclosed vehicle for many hours, high temperature inside the vehicle could cause fuel to vaporize resulting in a possible explosion.
- Do not drive on a rough road for an extended period with the generator on board. If you must transport the generator on a rough road, drain the fuel from the generator beforehand.

7.2 Before storing the unit for an extended period:

1. Be sure the storage area is free of excessive humidity and dust.
2. Drain the fuel.



Gasoline is extremely flammable and explosive under certain conditions.

Do not smoke or allow flames or sparks in the area.

3. Completely drain the fuel from the tank. Open the fuel valve, start the engine and operate it in the idle position until all remaining fuel is gone and the engine stops automatically.

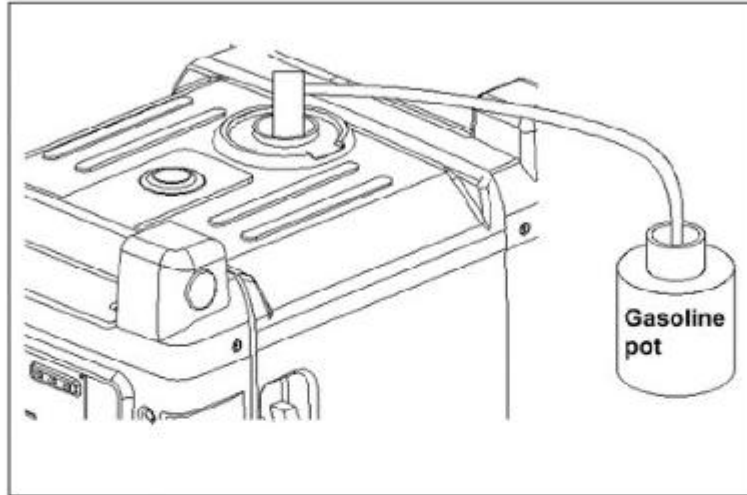

4. Discharge oil.
5. Remove spark plug and fill cylinder with 2cc's fresh oil. Pull start motor 3-4 times to discharge the remaining oil. Then reinstall the spark plug.
6. Pull the starting cord slowly until resistance is strong. At this time, the piston is moving to the top of the compression stroke and the valves will be closed.

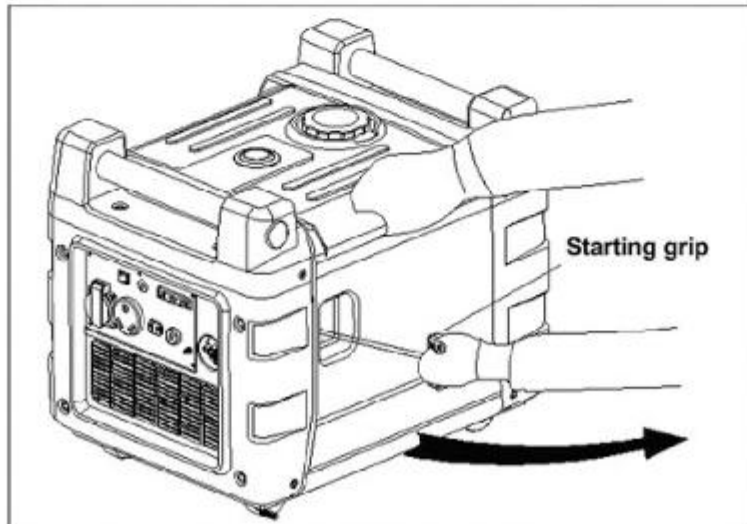

8 TROUBLESHOOTING

Engine will not start:

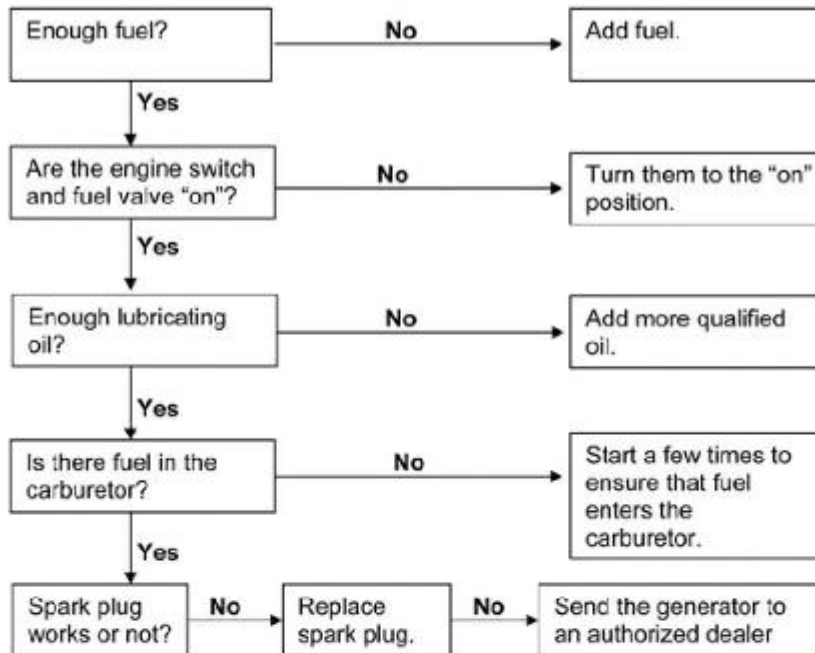

- Shake the generator several times to make the float rise if the generator cannot start after adding oil for the first time and the oil alarm indicator stays on when pulling the starting grip.
- Make sure there is no spilled fuel around the spark plug. Spilled fuel may ignite.
- If the engine still doesn't start, have the generator repaired by a licensed repair person.

Inspection:

1. Remove the spark plug rubber boot and clean any dirt from around the spark plug.
2. Remove the spark plug and place it in the spark plug rubber boot.
3. Connect the side electrode of the spark plug to the metal parts of the engine.
4. Pull the starting cord. A spark could jump across the gap.

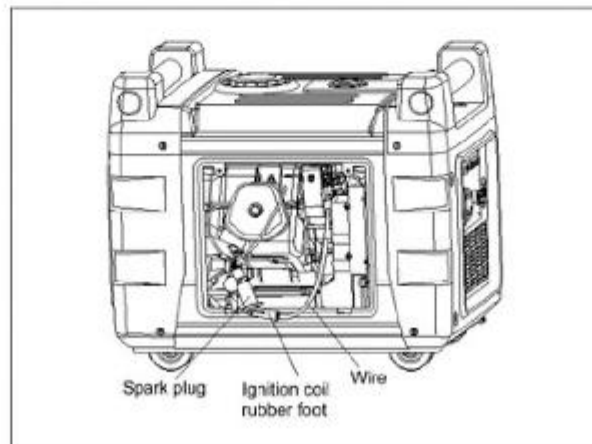

★ The equipment that connects generator doesn't start:

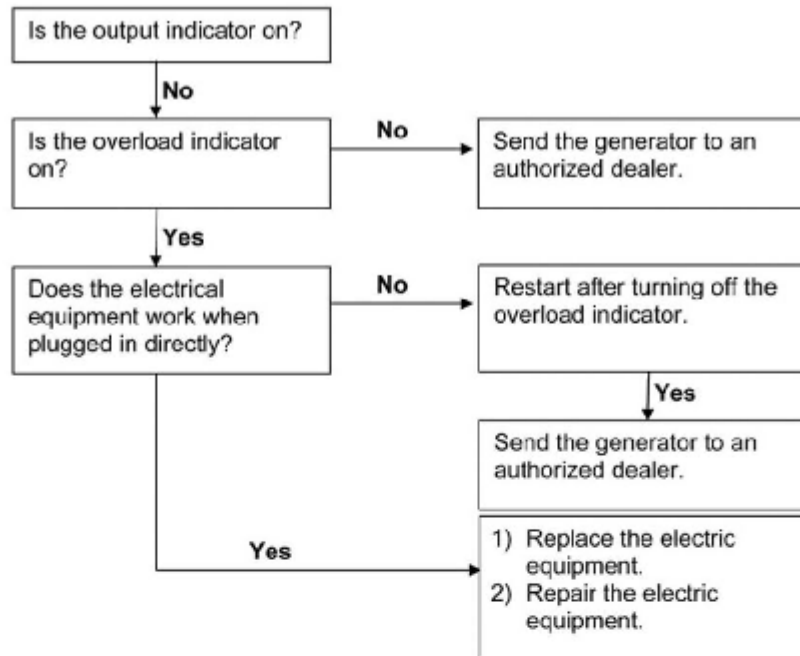

★ There is no power in the DC electric outlet:

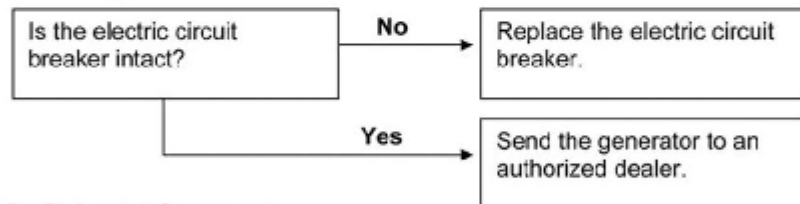

★ Deficient AC output

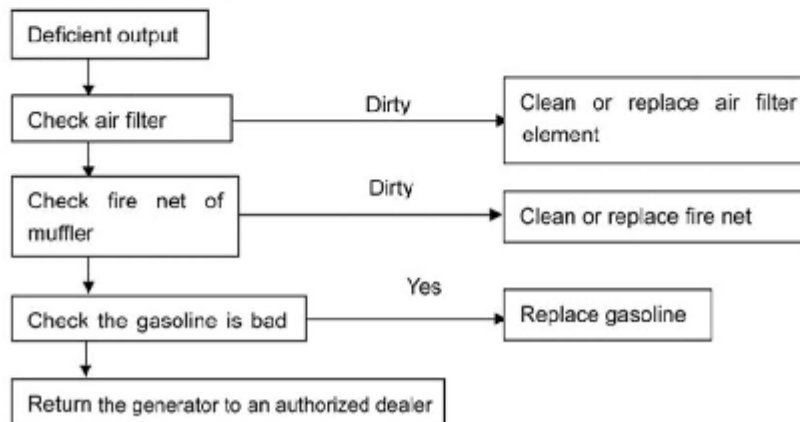

9. Specification

9.1 Size and weight

Item	SINEMATE 4500
L x W x H (mm)	600x450x500
Net weight	120 LBS

9.2 Engine

Item	SINEMATE 4500
Model	185F
Type	4-stroke, OHV, 1-cylinder
Displacement	269CC
Compression ratio	9.2
Engine speed	2200-3600rpm
Cooling system	Forced air cooling
Ignition system	T.D.I
Oil capacity	1.0L
Fuel tank capacity	14L
Spark plug	NGK
Noise level (4m)	59db

9.3 Generator

Type	Item	Generator Model No.
		SINEMATE 4500
AC output	Rated voltage (V)	120
	Rated frequency (HZ)	60
	Rated current (A)	27
	Rated output (KVA)	4.0
	Maximum output (KVA)	3.8
DC output (For 12V automotive batteries only)	Rated voltage (V)	12
	Rated current (A)	8.3



LIMITED WARRANTY

Applicable Products: RAMSOND SINEMATE 1000, 1500, 2500, 3500, and 4500 GASOLINE INVERTER GENERATORS.

Ramsond Corporation warrant the above referenced product, to the original purchaser of the above new equipment, to be free from defect or workmanship for a period of 1 year from the date of purchase, subject to the limitations contained herein. In the event of product failure or malfunction, return the product in person or by courier to:

Ramsond Corporation
WPC Service Department
4051 Haggerty Road
West Bloomfield, Michigan 48323
Tel: (248) 363-8302
Fax: (248) 363-7834

You must include the following to receive warranty service:

- Proof of purchase.
- Detailed description of the fault or problem
- Visible Serial Number of the unit
- \$35 Handling fee (check, money order)
- Return Shipping Label (prepaid) for returning to you the repaired/replaced product.

The faulty/defective product will then be repaired or replaced (at our option). The repaired/replaced component/product shall then be returned to the purchaser. The purchaser shall be responsible for all shipping and handling costs of sending the defective/faulty item to us, as well as all shipping and handling costs of returning the repaired/replaced to the customer. Any import/export costs associated with shipping of repaired product outside the United States, such as brokerage fees, taxes, customs or duties are the responsibility of the customer. Certain items which are subject to normal wear and tear are specifically excluded from this warranty (e.g. spark plug, and filters). Please allow up to 30 days from date that we receive the unit for repair/replacement. In the event that we are not able to repair the product, we will replace the product with same or similar unit. In the event that the model is not available, we will replace the machine with an existing model with same or better characteristics, functionality and quality. We reserve the right to replace a defective unit with an identical refurbished unit that has been subjected to testing, which will similarly be warranted against defect or workmanship. Faulty installation, operation or maintenance of the product or attempted repair and maintenance by persons not expressly certified by Ramsond shall render the limited warranty void. Damage resulting from failure to use the product in a manner consistent with our recommendations shall render the limited warranty void. This limited warranty specifically excludes any consequential and/or incidental damages. Although we may provide technical assistance via telephone or email to the customer, it is virtually impossible to troubleshoot all matters via telephone or remote assistance. As such, the offering by us of any technical assistance is made without any warranty or guarantee and provided on "as is" basis. It is the responsibility of each purchaser to determine whether any particular product is compliant with and permissible for use pursuant to the applicable rules, codes and/or regulations, if any, and suitable for particular use and operation. We make no representations or warranties whatsoever concerning the suitability of any merchandise for a particular use or purpose and any such warranty is expressly excluded from the terms of this limited warranty. We reserve the right to make slight modifications necessary to the merchandise for product improvement. This limited warranty shall be subject the laws of the State of Michigan and any claiming arising therefrom shall be interpreted in accordance to the laws of the State of Michigan and subject to the exclusive jurisdiction of the Courts of State of Michigan.

WIRING DIAGRAM

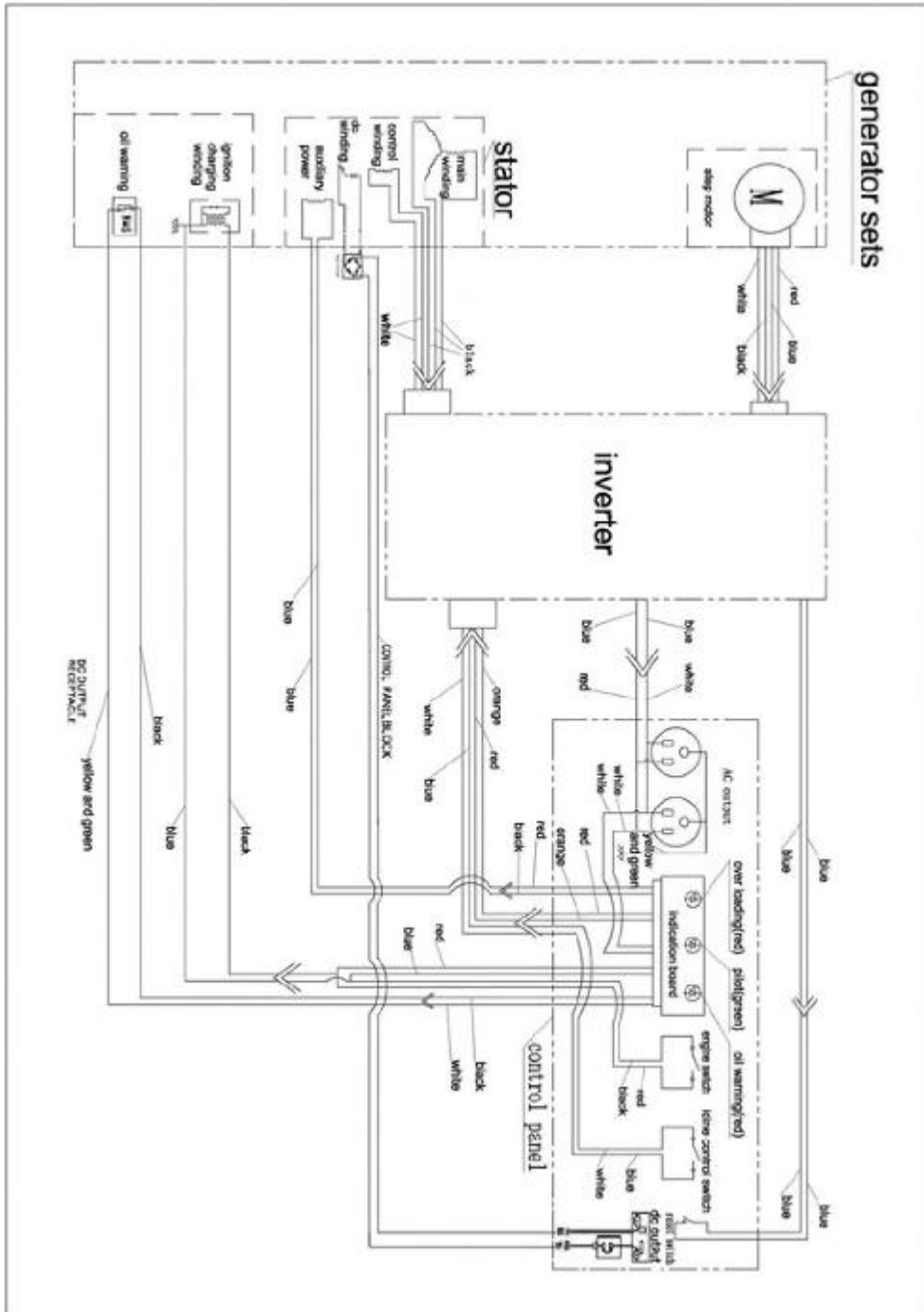

EXPLODED PARTS VIEW

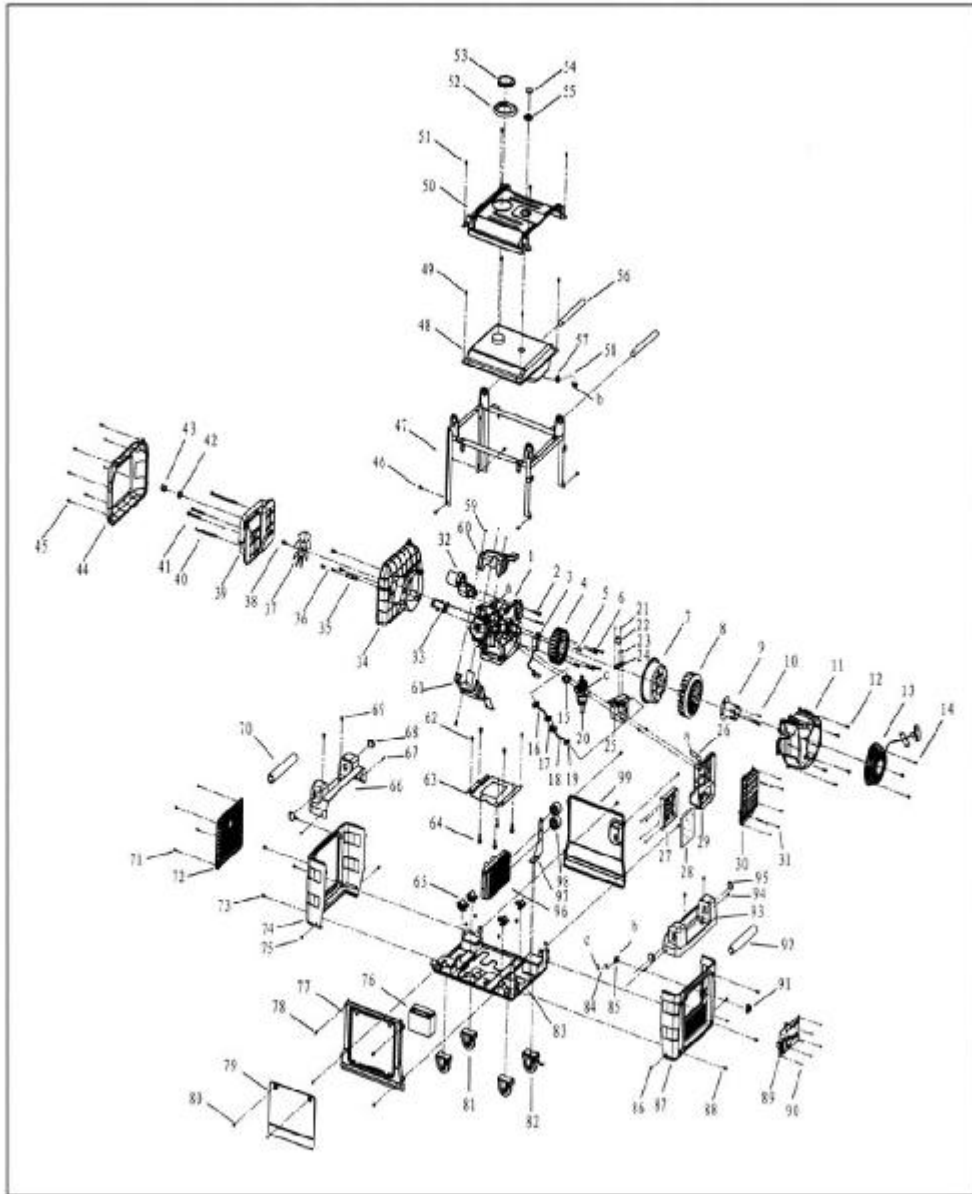

PARTS LIST

Item No.	Name	Item No.	Name
1.	Engine Assembly	50.	Top Cover
2.	M8 X 40 Bolt	51.	M6 X 12 Bolt
3.	Ignition Coil	52.	Fuel Tank Sleeve
4.	Stator Assembly	53.	Fuel Cap
5.	M6 X 25 Bolt	54.	Fuel Level Display Cover board
6.	M6 X50 Inner 6 Cornus Bolt	55.	Fuel Level Display Sleeve
7.	Rotor Assembly	56.	Handle
8.	Flywheel Fan	57.	Sheet Iron Clip
9.	Starter Cup	58.	Connection Pipe, Fuel Tank
10.	M6 X 20 Bolt	59.	M4.2 X 10 Self- tapping Screw
11.	Motor Wind Cover	60.	Upper Fan Cover
12.	M6 X 18 Bolt	61.	Nether Fan Cover
13.	Recoil Starter Assembly	62.	M8 X 15 Bolt
14.	M6 X 10 Bolt	63.	Engine Bracket
15.	Carburetor Gasket, Plastic	64.	M10 X 30 Bolt
16.	Connection Pipe for Carburetor Gasket, Plastic	65.	Absorber
17.	Backpressure Valve	66.	Rear Cover
18.	Connection Pipe for Choke	67.	M6 X 12 Plate Screw
19.	Steel Wire Clip	68.	Handle stopple
20.	Carburetor	69.	M6 X 12 Bolt
21.	M3 X 8 Obtuse Screw	70.	Handle Sponge Sleeve
22.	Step Motor	71.	M6 X 12 Bolt
23.	M5 X 8 Plate Screw	72.	Exhaust Cover
24.	Step Motor, Base	73.	M6 X 12 Bolt
25.	Choke Frame	74.	Rear Housing
26.	Breath Pipe	75.	M6 X 12 Plate Screw
27.	Air Cleaner Cartridge	76.	Battery
28.	Air Cleaner Element	77.	Lift Side Board
29.	Air Cleaner Case	78.	M6 X 12 Bolt
30.	Air Cleaner Cover	79.	Maintenance Cover
31.	M4. 2 X 12 Self-tapping Screw	80.	M6 X 12 Big Head Bolt
32.	Starting Motor	81.	Common Wheels
33.	Muffler Bent Tube	82.	Wheels with Brake
34.	Muffler Cover	83.	Underpan
35.	Muffler Cover Frame, Firmed Frame	84.	Carburetor Connection Pipe
36.	M6 X 12 Bolt	85.	Fuel Valve
37.	Fan	86.	M6 X 12 Plate Screw
38.	M10 X 20 Bolt	87.	Front Housing
39.	Muffler Assembly	88.	M6 X 12 Bolt
40.	M8 X 165 Bolt	89.	Control Panel Assembly
41.	M8 X 85 Bolt	90.	M4.2 X 10 Self- tapping Screw
42.	Clip	91.	Fuel Valve Knob
43.	Fire Net	92.	Handle Sponge Sleeve
44.	Muffler Cover	93.	Front Cover
45.	M6 X 16 Plate Screw	94.	M6 X 12 Plate Screw
46.	M6 X 12 Bolt	95.	Handle stopple
47.	Frame	96.	Inverter Assembly
48.	Fuel Tank	97.	Inverter Bracket
49.	M6 X 12 Bolt	98.	Inductance
		99.	Right Side Board



LIMITED WARRANTY

Applicable Products: RAMSOND SINEMATE 1000, 1500, 2500, 3500, and 4500 GASOLINE INVERTER GENERATORS.

Ramsond Corporation warrant the above referenced product, to the original purchaser of the above new equipment, to be free from defect or workmanship for a period of 1 year from the date of purchase, subject to the limitations contained herein. In the event of product failure or malfunction, return the product in person or by courier to:

Ramsond Corporation
WPC Service Department
4051 Haggerty Road
West Bloomfield, Michigan 48323
Tel: (248) 363-8302
Fax: (248) 363-7834

You must include the following to receive warranty service:

- Proof of purchase.
- Detailed description of the fault or problem
- Visible Serial Number of the unit
- \$35 Handling fee (check, money order)
- Return Shipping Label (prepaid) for returning to you the repaired/replaced product.

The faulty/defective product will then be repaired or replaced (at our option). The repaired/replaced component/product shall then be returned to the purchaser. The purchaser shall be responsible for all shipping and handling costs of sending the defective/faulty item to us, as well as all shipping and handling costs of returning the repaired/replaced to the customer. Any import/export costs associated with shipping of repaired product outside the United States, such as brokerage fees, taxes, customs or duties are the responsibility of the customer. Certain items which are subject to normal wear and tear are specifically excluded from this warranty (e.g. spark plug, and filters). Please allow up to 30 days from date that we receive the unit for repair/replacement. In the event that we are not able to repair the product, we will replace the product with same or similar unit. In the event that the model is not available, we will replace the machine with an existing model with same or better characteristics, functionality and quality. We reserve the right to replace a defective unit with an identical refurbished unit that has been subjected to testing, which will similarly be warranted against defect or workmanship. Faulty installation, operation or maintenance of the product or attempted repair and maintenance by persons not expressly certified by Ramsond shall render the limited warranty void. Damage resulting from failure to use the product in a manner consistent with our recommendations shall render the limited warranty void. This limited warranty specifically excludes any consequential and/or incidental damages. Although we may provide technical assistance via telephone or email to the customer, it is virtually impossible to troubleshoot all matters via telephone or remote assistance. As such, the offering by us of any technical assistance is made without any warranty or guarantee and provided on "as is" basis. It is the responsibility of each purchaser to determine whether any particular product is compliant with and permissible for use pursuant to the applicable rules, codes and/or regulations, if any, and suitable for particular use and operation. We make no representations or warranties whatsoever concerning the suitability of any merchandise for a particular use or purpose and any such warranty is expressly excluded from the terms of this limited warranty. We reserve the right to make slight modifications necessary to the merchandise for product improvement. This limited warranty shall be subject the laws of the State of Michigan and any claiming arising therefrom shall be interpreted in accordance to the laws of the State of Michigan and subject to the exclusive jurisdiction of the Courts of State of Michigan.